



Lecture 9

- AC Power Calculation



Outline

- Instantaneous power
- Average power
- Apparent power
- Power factor
- Complex power

AC Power in Time Domain: Instantaneous

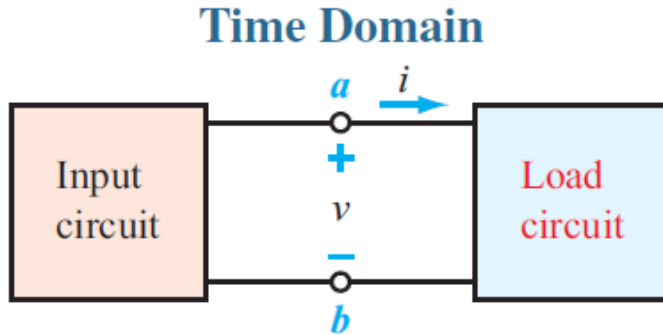

$$v(t) = V_m \cos(\omega t + \theta_v) \quad i(t) = I_m \cos(\omega t + \theta_i)$$

Instantaneous power:
power at any instant of time.

$$p(t) = v(t)i(t) = V_m I_m \cos(\omega t + \theta_v) \cos(\omega t + \theta_i)$$

$$p(t) = \frac{1}{2} V_m I_m \cos(\theta_v - \theta_i) + \frac{1}{2} V_m I_m \cos(2\omega t + \theta_v + \theta_i)$$



AC Power in Time Domain: Instantaneous

$$p(t) = \frac{1}{2}V_m I_m \cos(\theta_v - \theta_i) + \frac{1}{2}V_m I_m \cos(2\omega t + \theta_v + \theta_i)$$

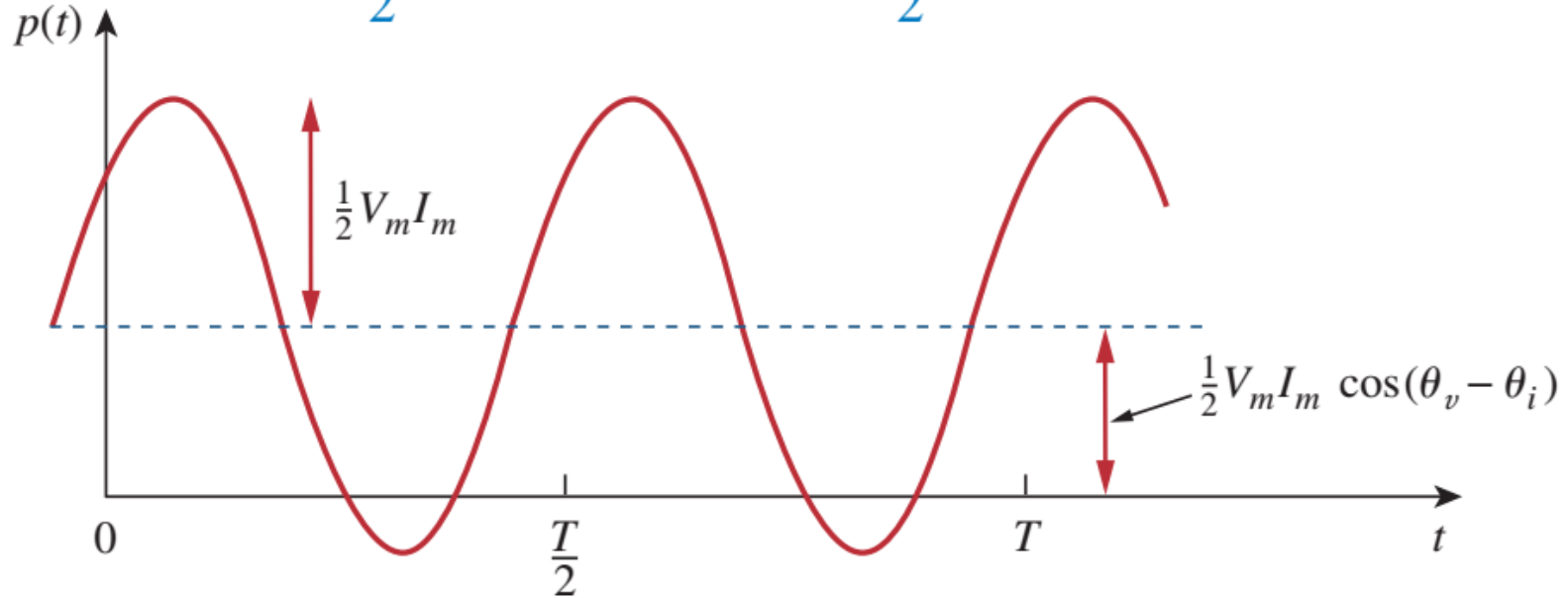



Average Power P (Capitalized)

$$v(t) = V_m \cos(\omega t + \theta_v) \quad i(t) = I_m \cos(\omega t + \theta_i)$$

$$p(t) = \frac{1}{2} V_m I_m \cos(\theta_v - \theta_i) + \frac{1}{2} V_m I_m \cos(2\omega t + \theta_v + \theta_i)$$

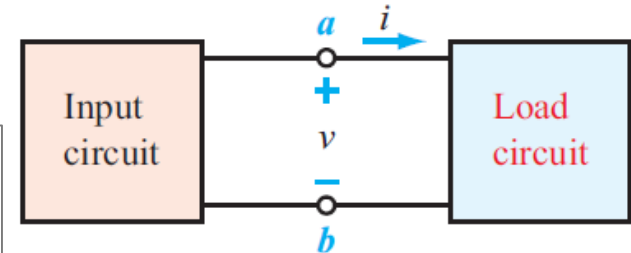

Average (or real) power (unit: **watts**)

The **average power**, in watts, is the average of the instantaneous power over one period.

$$P = \frac{1}{T} \int_0^T p(t) dt$$



Average Power P (time domain)

$$\begin{aligned} P &= \frac{1}{T} \int_0^T \frac{1}{2} V_m I_m \cos(\theta_v - \theta_i) dt \\ &+ \frac{1}{T} \int_0^T \frac{1}{2} V_m I_m \cos(2\omega t + \theta_v + \theta_i) dt \\ &= \frac{1}{2} V_m I_m \cos(\theta_v - \theta_i) \frac{1}{T} \int_0^T dt \\ &+ \frac{1}{2} V_m I_m \frac{1}{T} \int_0^T \cos(2\omega t + \theta_v + \theta_i) dt \end{aligned}$$

$$P = \frac{1}{2} V_m I_m \cos(\theta_v - \theta_i)$$



Average Power P (phasor domain)

$$v(t) = V_m \cos(\omega t + \theta_v) \quad i(t) = I_m \cos(\omega t + \theta_i)$$

$$\mathbf{V} = V_m \angle \theta_v \quad \text{and} \quad \mathbf{I} = I_m \angle \theta_i,$$

$$\frac{1}{2} \mathbf{V} \mathbf{I}^* = \frac{1}{2} V_m I_m \angle \theta_v - \theta_i$$

$$= \frac{1}{2} V_m I_m [\cos(\theta_v - \theta_i) + j \sin(\theta_v - \theta_i)]$$

$$P = \frac{1}{2} \text{Re}[\mathbf{V} \mathbf{I}^*] = \frac{1}{2} V_m I_m \cos(\theta_v - \theta_i)$$



Two special cases for average power P

$$P = \frac{1}{2} \operatorname{Re}[\mathbf{V}\mathbf{I}^*] = \frac{1}{2} V_m I_m \cos(\theta_v - \theta_i)$$

- For a purely resistive load R :

$$P = \frac{1}{2} V_m I_m = \frac{1}{2} I_m^2 R = \frac{1}{2} |\mathbf{I}|^2 R \quad \text{where } |\mathbf{I}|^2 = \mathbf{I} \times \mathbf{I}^*$$

- For a purely reactive load:

$$P = \frac{1}{2} V_m I_m \cos 90^\circ = 0$$



Resistive vs. Inductive

$$p(t) = \frac{1}{2} V_m I_m \cos(\theta_v - \theta_i) + \frac{1}{2} V_m I_m \cos(2\omega t + \theta_v + \theta_i)$$

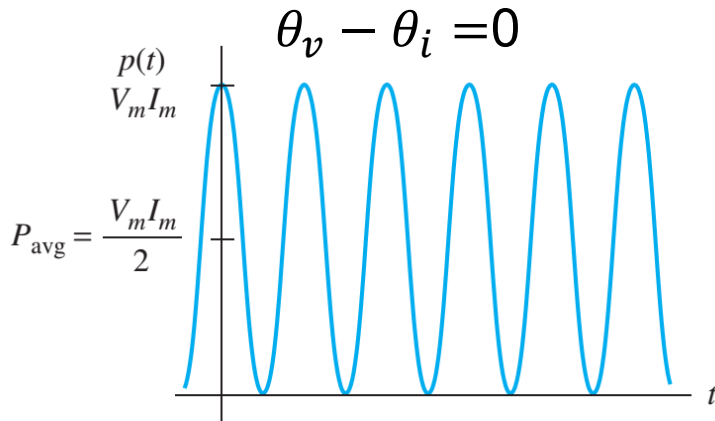

Pure resistive load

$$P_{avg} = \frac{V_m I_m}{2}$$

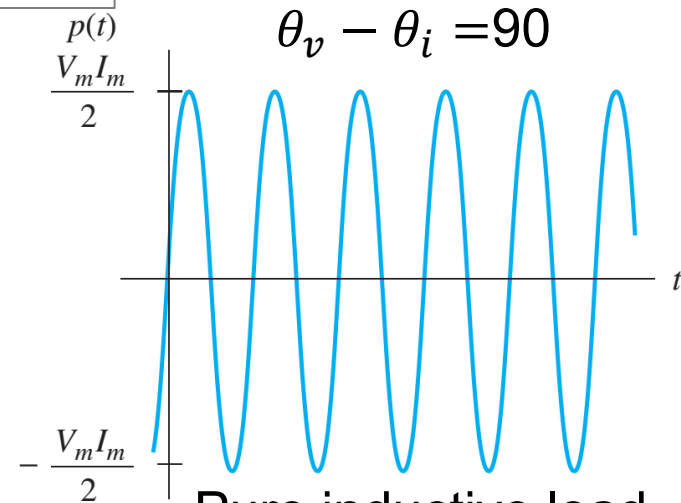

Pure inductive load

$$P_{avg} = 0$$

A resistive load (R) absorbs power at all times, while a reactive load (L or C) absorbs zero average power.

Half the time, the energy is delivered to the inductance;
The other half time, energy is returned to the source.



Effective Value (RMS) *Root Mean Square* of periodic signal

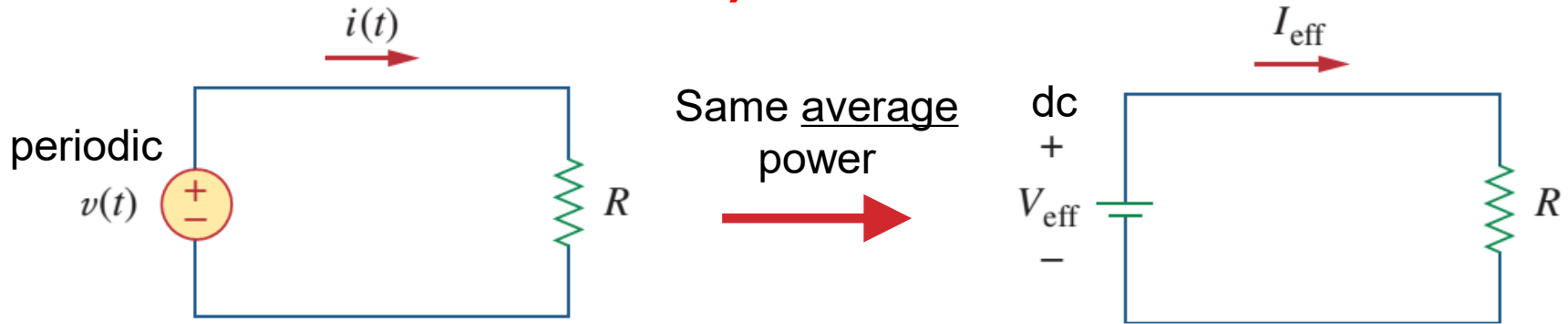

- For any periodic function $x(t)$ in general, its rms value is

$$X_{\text{eff}} = X_{\text{rms}} = \sqrt{\frac{1}{T} \int_0^T x^2(t) dt}$$

$$V_{\text{eff}} = \sqrt{\frac{1}{T} \int_0^T v^2(t) dt}$$

$$I_{\text{eff}} = \sqrt{\frac{1}{T} \int_0^T i^2(t) dt}$$

RMS of a sinusoidal signal

- The RMS value of $v(t) = V_m \cos(\omega t + \phi)$ is

$$\begin{aligned} V_{\text{rms}} &= \sqrt{\frac{1}{T} \int_{t_0}^{t_0+T} v^2(t) dt} \\ &= \sqrt{\frac{1}{T} \int_{t_0}^{t_0+T} V_m^2 \cdot \cos^2(\omega t + \phi) dt} \\ &= \frac{V_m}{\sqrt{2}} \end{aligned}$$

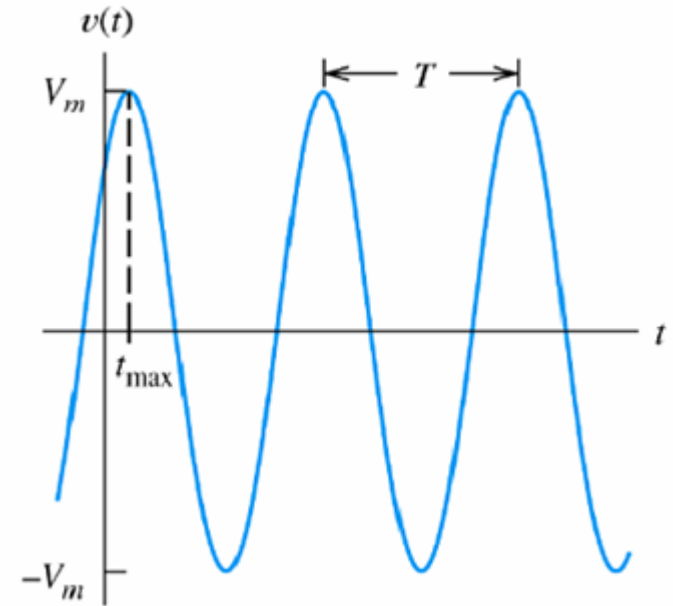

Average
Power

$$\begin{aligned} P &= \frac{1}{2} V_m I_m \cos(\theta_v - \theta_i) = \frac{V_m}{\sqrt{2}} \frac{I_m}{\sqrt{2}} \cos(\theta_v - \theta_i) \\ &= V_{\text{rms}} I_{\text{rms}} \cos(\theta_v - \theta_i) \end{aligned}$$



Outline

- Instantaneous power
- Average power
- Apparent power
- Power factor
- Complex power



Apparent Power

$$P = \frac{1}{2} V_m I_m \cos(\theta_v - \theta_i) = \frac{V_m}{\sqrt{2}} \frac{I_m}{\sqrt{2}} \cos(\theta_v - \theta_i) \\ = V_{\text{rms}} I_{\text{rms}} \cos(\theta_v - \theta_i)$$

$$S \text{ or } S_a = V_{\text{rms}} I_{\text{rms}}$$

Unit: volt-amp (VA)

It seems apparent that the power should be the voltage-current product, *by analogy with dc resistive circuits.*



Power Factor

$$P = \frac{1}{2} V_m I_m \cos(\theta_v - \theta_i) = \frac{V_m}{\sqrt{2}} \frac{I_m}{\sqrt{2}} \cos(\theta_v - \theta_i) \\ = V_{\text{rms}} I_{\text{rms}} \cos(\theta_v - \theta_i)$$

- The power factor

$$\text{pf} = \frac{P}{S_a} = \cos(\theta_v - \theta_i)$$

- $(\theta_v - \theta_i)$ is called power factor angle.
 - >0 means a *lagging* pf (current lags voltage)
 - <0 means a *leading* pf (current leads voltage)
- pf ranges from 0 to 1.



Power Factor-2

$$P = \frac{1}{2} V_m I_m \cos(\theta_v - \theta_i) = \frac{V_m}{\sqrt{2}} \frac{I_m}{\sqrt{2}} \cos(\theta_v - \theta_i) \\ = V_{\text{rms}} I_{\text{rms}} \cos(\theta_v - \theta_i)$$

- The power factor

$$\text{pf} = \frac{P}{S} = \cos(\theta_v - \theta_i)$$

- $(\theta_v - \theta_i)$ is called power factor angle.
- $(\theta_v - \theta_i)$ is equal to the angle of the load impedance

$$\mathbf{Z} = \frac{\mathbf{V}}{\mathbf{I}} = \frac{V_m \angle \theta_v}{I_m \angle \theta_i} = \frac{V_m}{I_m} \angle \theta_v - \theta_i$$

Also
$$\mathbf{Z} = \frac{\mathbf{V}}{\mathbf{I}} = \frac{V_{\text{rms}}}{I_{\text{rms}}} \angle \theta_v - \theta_i$$

Power Factor-3

$$\mathbf{Z} = \frac{\mathbf{V}}{\mathbf{I}} = \frac{V_m \angle \theta_v}{I_m \angle \theta_i} = \frac{V_m}{I_m} \angle \theta_v - \theta_i$$

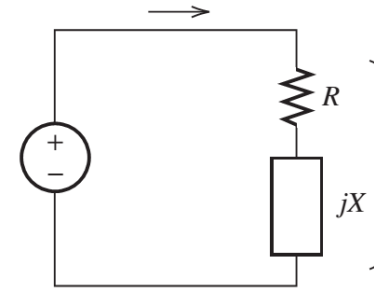

Power factor leading and lagging relationships for a load $\mathbf{Z} = R + jX$.

Load Type	$\phi_z = (\theta_v - \theta_i)$	I-V Relationship	pf
Purely Resistive ($X = 0$)	$\phi_z = 0$	I in-phase with V	1
Inductive ($X > 0$)	$0 < \phi_z \leq 90^\circ$	I lags V	lagging
Purely Inductive ($X > 0$ and $R = 0$)	$\phi_z = 90^\circ$	I lags V by 90°	lagging
Capacitive ($X < 0$)	$-90^\circ \leq \phi_z < 0$	I leads V	leading
Purely Capacitive ($X < 0$ and $R = 0$)	$\phi_z = -90^\circ$	I leads V by 90°	leading



Outline

- Instantaneous power
- Average power
- Apparent power
- Power factor
- **Complex power**



Complex Power

$$v(t) = V_m \cos(\omega t + \theta_v) \Rightarrow \mathbf{V} = V_m \angle \theta_v$$

$$i(t) = I_m \cos(\omega t + \theta_i) \Rightarrow \mathbf{I} = I_m \angle \theta_i$$

We observe that:

$$\begin{aligned} \frac{1}{2} \mathbf{V} \mathbf{I}^* &= \frac{1}{2} V_m I_m \angle (\theta_v - \theta_i) \\ &= \frac{1}{2} V_m I_m \cos(\theta_v - \theta_i) + j \frac{1}{2} V_m I_m \sin(\theta_v - \theta_i) \end{aligned}$$

- Define a **single power metric**

$$\mathbf{S} = \frac{1}{2} \mathbf{V} \mathbf{I}^* = \mathbf{V}_{\text{rms}} \mathbf{I}_{\text{rms}}^* = V_{\text{rms}} I_{\text{rms}} \angle (\theta_v - \theta_i) = P + jQ$$

Unit: volt-amp (VA)

Complex power is important in power analysis because it contains *all* the information pertaining to the power absorbed by a given load.



Another Way to Calculate Complex Power using impedance

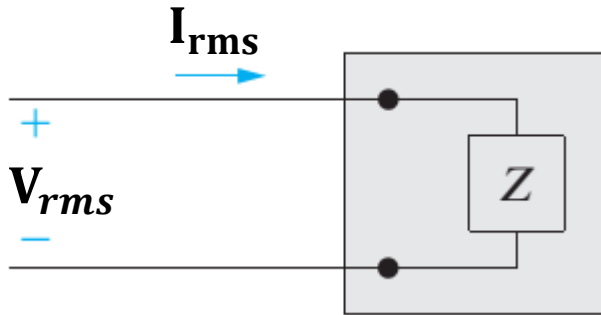

$$\mathbf{V}_{\text{rms}} = \mathbf{I}_{\text{rms}} \mathbf{Z}$$



$$\begin{aligned} \mathbf{S} &= \mathbf{V}_{\text{rms}} \mathbf{I}_{\text{rms}}^* \\ &= \mathbf{V}_{\text{rms}} \left(\frac{\mathbf{V}_{\text{rms}}}{\mathbf{Z}} \right)^* \\ &= \frac{|\mathbf{V}_{\text{rms}}|^2}{\mathbf{Z}^*} \end{aligned}$$

$$\begin{aligned} \mathbf{S} &= \mathbf{V}_{\text{rms}} \mathbf{I}_{\text{rms}}^* \\ &= \mathbf{I}_{\text{rms}} \mathbf{Z} \mathbf{I}_{\text{rms}}^* \\ &= |\mathbf{I}_{\text{rms}}|^2 \mathbf{Z} \\ &= |\mathbf{I}_{\text{rms}}|^2 (R + jX) \\ &= |\mathbf{I}_{\text{rms}}|^2 R + j |\mathbf{I}_{\text{rms}}|^2 X \\ &= I_{\text{rms}}^2 R + j I_{\text{rms}}^2 X \end{aligned}$$

$$\mathbf{S} = I_{\text{rms}}^2 \mathbf{Z} = \frac{V_{\text{rms}}^2}{\mathbf{Z}^*} = \mathbf{V}_{\text{rms}} \mathbf{I}_{\text{rms}}^*$$

$$P = \text{Re}(\mathbf{S}) = I_{\text{rms}}^2 R$$

$$Q = \text{Im}(\mathbf{S}) = I_{\text{rms}}^2 X$$

Power Triangle

$$P = \text{Re}(S) = I_{\text{rms}}^2 R$$

$$Q = \text{Im}(S) = I_{\text{rms}}^2 X$$

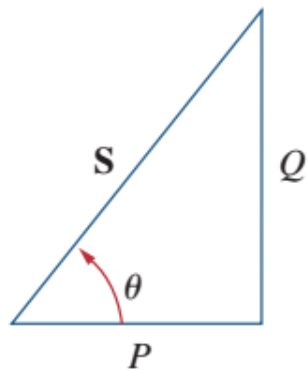

(a)

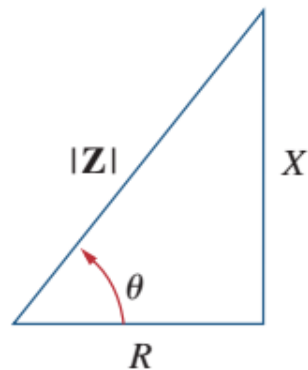

(b)

Figure 11.21

(a) Power triangle, (b) impedance triangle.

Quantity	Units
Complex power	volt-amps
Average power	watts
Reactive power	var



$$\mathbf{S} = \frac{1}{2} \mathbf{V} \mathbf{I}^* = \mathbf{V}_{\text{rms}} \mathbf{I}_{\text{rms}}^* = V_{\text{rms}} I_{\text{rms}} \angle(\theta_v - \theta_i) = P + jQ$$

$$P = \text{Re}(\mathbf{S}) = I_{\text{rms}}^2 R$$

$$Q = \text{Im}(\mathbf{S}) = I_{\text{rms}}^2 X$$

- Average (or real) power

$$P = \text{Re}\left[\frac{1}{2} \mathbf{V} \mathbf{I}^*\right]$$

Unit: W

- Reactive power

$$Q = \text{Im}\left[\frac{1}{2} \mathbf{V} \mathbf{I}^*\right]$$

Unit: Volt Amperes Reactive (VAR)

- Apparent power

$$S = |\mathbf{S}| = \frac{1}{2} V_m I_m = V_{\text{rms}} I_{\text{rms}}$$

Unit: volt-amp (VA)



Short summary

$$\text{Complex Power} = \mathbf{S} = P + jQ = \mathbf{V}_{\text{rms}}(\mathbf{I}_{\text{rms}})^*$$

$$= |\mathbf{V}_{\text{rms}}| |\mathbf{I}_{\text{rms}}| \angle \theta_v - \theta_i$$

$$\text{Apparent Power} = S = |\mathbf{S}| = |\mathbf{V}_{\text{rms}}| |\mathbf{I}_{\text{rms}}| = \sqrt{P^2 + Q^2}$$

$$\text{Real Power} = P = \text{Re}(\mathbf{S}) = S \cos(\theta_v - \theta_i)$$

$$\text{Reactive Power} = Q = \text{Im}(\mathbf{S}) = S \sin(\theta_v - \theta_i)$$

$$\text{Power Factor} = \frac{P}{S} = \cos(\theta_v - \theta_i)$$



Reactive Power Q

Let us look at Instantaneous power again

$$p(t) = v(t)i(t)$$
$$p(t) = p_R(t) + p_X(t)$$
$$p_R(t) =$$
$$p_X(t) =$$

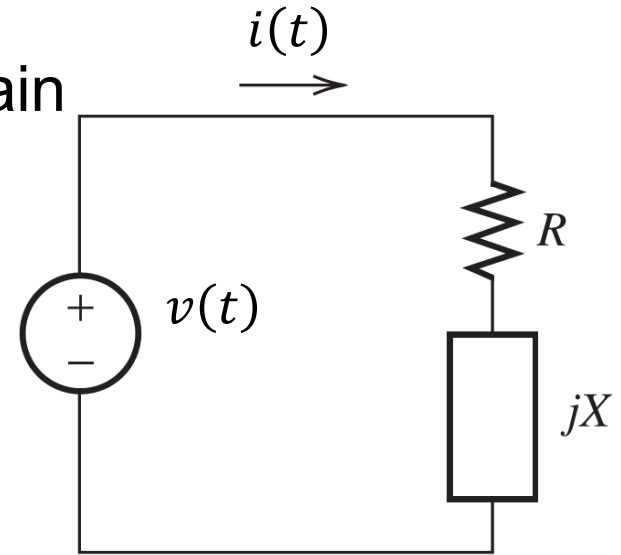

Reactive Power Q : Peak Exchanged Power

- Definition: The peak instantaneous power associated with the energy storage elements contained in a general load.

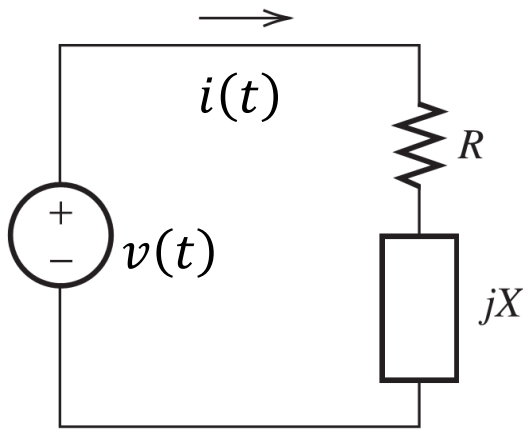

$$Q = \frac{1}{2} V_m I_m \sin(\theta_v - \theta_i) = V_{rms} I_{rms} \sin(\theta_v - \theta_i)$$

$$Q = \begin{cases} 0 & \text{for resistive } (\theta_v - \theta_i = 0^\circ) \\ \frac{1}{2} V_m I_m & \text{for inductive } (\theta_v - \theta_i = 90^\circ) \\ -\frac{1}{2} V_m I_m & \text{for capacitive } (\theta_v - \theta_i = -90^\circ) \end{cases}$$

- Reactive power is still of concern to power-system engineers
 - Transmission lines/transformers/fuses et al. must be capable of withstanding the current associated with reactive power.



Example

- Find the average power and reactive power absorbed by an impedance $Z = 30 - j70\Omega$, when a voltage $V_m = 120\angle 0^\circ$ is applied across it.

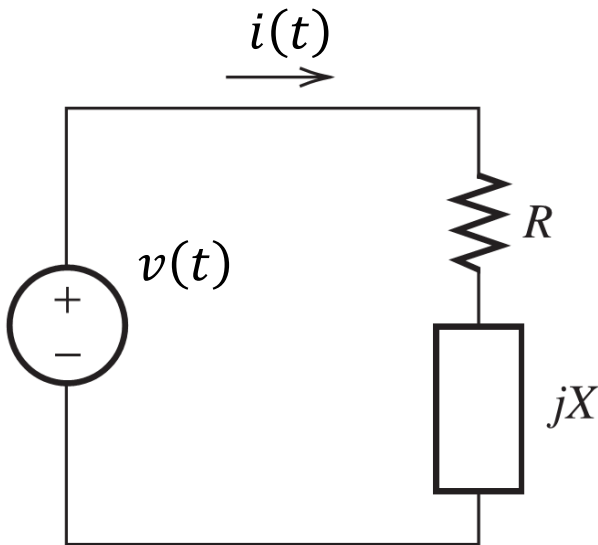

Example

- Find the average power and reactive power absorbed by an impedance $Z = 30 - j70\Omega$, when a voltage $V_m = 120\angle 0^\circ$ is applied across it.

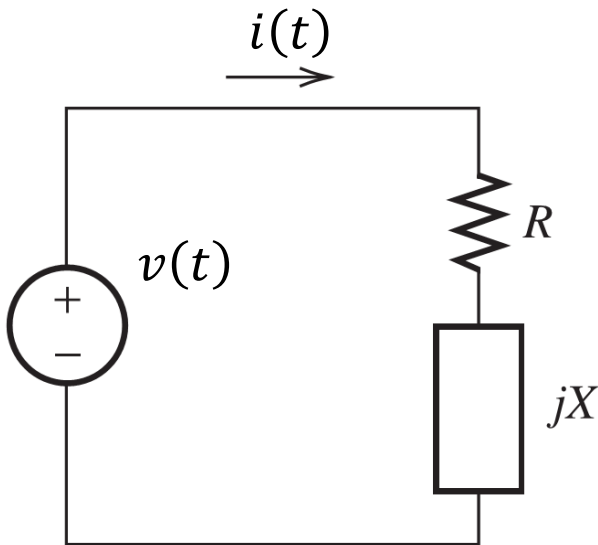

$$\begin{aligned} \mathbf{I}_m &= \frac{\mathbf{V}_m}{Z} = \frac{120\angle 0^\circ}{30 - j70} = \frac{120\angle 0^\circ}{76.16\angle -66.8^\circ} \\ &= 1.576\angle 66.8^\circ \text{ A} \end{aligned}$$

$$P = \frac{1}{2} V_m I_m \cos(\theta_v - \theta_i) = 37.24 \text{ W}$$

$$Q = \frac{1}{2} V_m I_m \sin(\theta_v - \theta_i) = -86.91 \text{ VAR}$$



Example

- A series-connected load draws a current

$$i(t) = 4\cos(100\pi t + 10^\circ)\text{A}$$

when the applied voltage is

$$v(t) = 120\cos(100\pi t - 20^\circ)\text{V}$$

- Find the apparent power and the power factor of the load.
- Determine the values that form the series-connected load.

$$V_{\text{rms}}I_{\text{rms}} = 240 \text{ VA}$$

$$\text{pf} = \cos(\theta_v - \theta_i) = 0.866 \quad (\text{leading})$$

$$\mathbf{Z} = \frac{\mathbf{V}}{\mathbf{I}} = 25.98 - j15 \Omega$$

$$C = \frac{1}{15\omega} = \frac{1}{15 \times 100\pi} = 212.2 \mu\text{F}$$



Exercise

- The voltage across a load is $v(t) = 60\cos(\omega t - 10^\circ)V$, and the current through the load is $i(t) = 1.5\cos(\omega t + 50^\circ)$. Find
 - The complex and apparent powers.
 - The real and reactive powers.
 - The power factor and the load impedance.



Exercise

- The voltage across a load is $v(t) = 60\cos(\omega t - 10^\circ)V$, and the current through the load is $i(t) = 1.5\cos(\omega t + 50^\circ)$. Find
 - The complex and apparent powers.
 - The real and reactive powers.
 - The power factor and the load impedance.

$$\mathbf{S} = \mathbf{V}_{\text{rms}} \mathbf{I}_{\text{rms}}^* = 45 \angle -60^\circ \text{ VA}$$

$$\text{pf} = 0.5 \text{ (leading)}$$

$$\mathbf{Z} = \frac{\mathbf{V}}{\mathbf{I}} = 40 \angle -60^\circ \Omega$$



Example

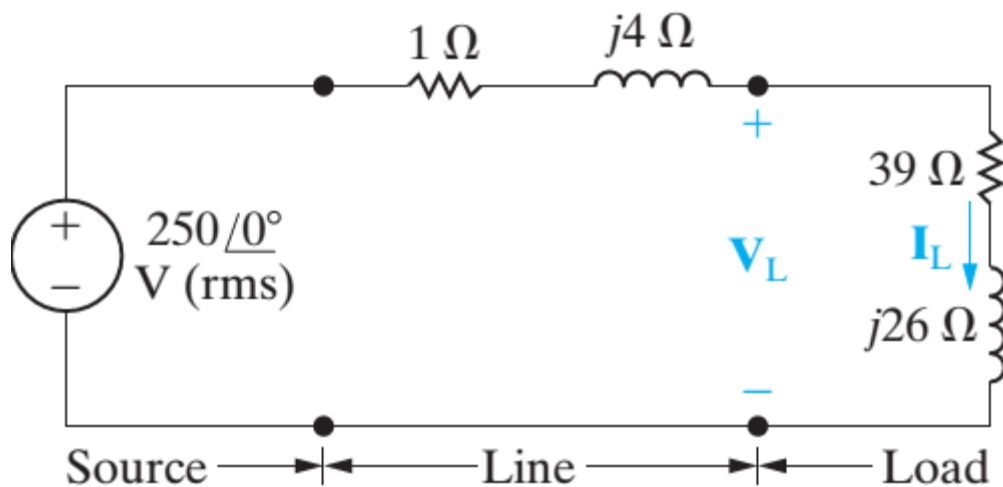

- Find V_L and I_L .
- Find the average and reactive power
 - Delivered to the load
 - Delivered to the line
 - Supplied by the source

Example

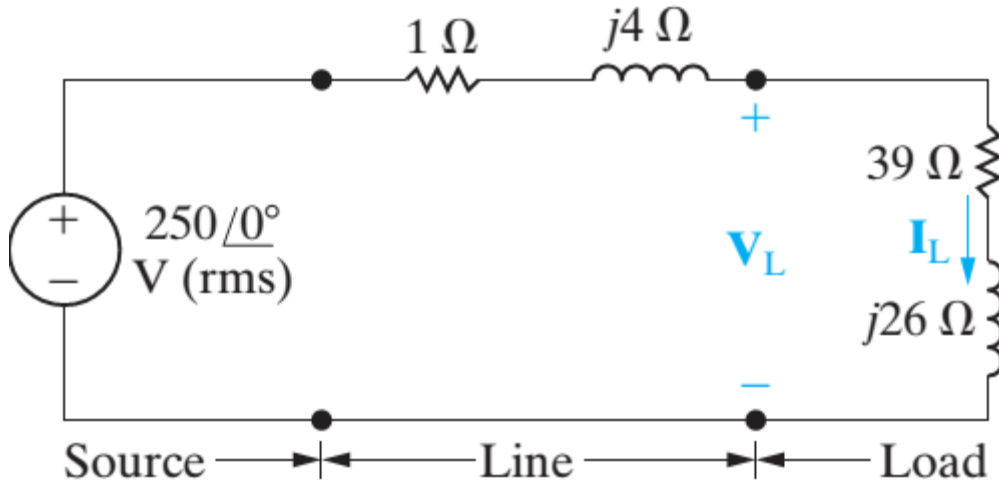

- Find V_L and I_L .
- Find the average and reactive power
 - Delivered to the load
 - Delivered to the line
 - Supplied by the source

$$\begin{aligned} I_L &= \frac{250\angle 0^\circ}{40 + j30} = 4 - j3 \\ &= 5\angle -36.87^\circ \text{ (rms)} \end{aligned}$$

$$\begin{aligned} V_L &= I_L(39 + j26) \\ &= 234 - j13 \\ &= 234.36\angle -3.18^\circ \end{aligned}$$

Load:

$$V_L I_L^* = 975 + j650 \text{ VA}$$

Line:

$$P = (5)^2(1) = 25 \text{ W}$$

$$Q = (5)^2(4) = 100 \text{ VAR}$$

Source:

$$250\angle 0^\circ I_L^* = 1000 + j750 \text{ VA}$$



Complex Power

Time Domain

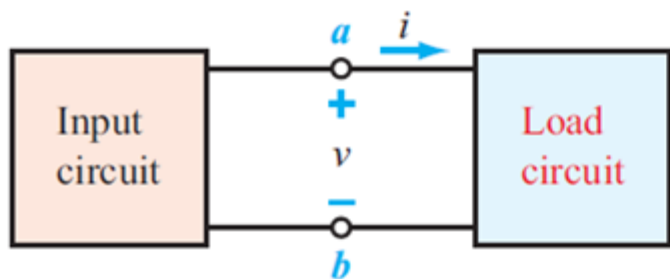

$$v(t) = V_m \cos(\omega t + \phi_v)$$

$$i(t) = I_m \cos(\omega t + \phi_i)$$

$$V_{\text{rms}} = V_m / \sqrt{2}$$

$$I_{\text{rms}} = I_m / \sqrt{2}$$

Phasor Domain

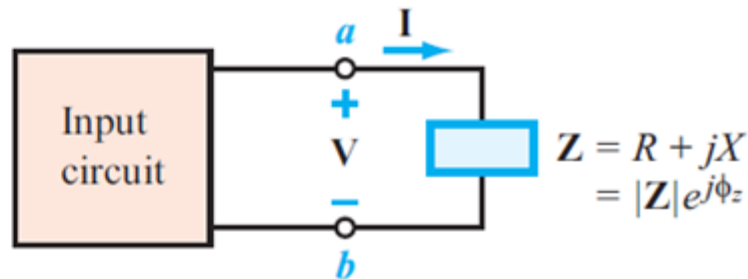

$$V = V_m e^{j\phi_v}$$

$$I = I_m e^{j\phi_i}$$

$$V_{\text{rms}} = V_m e^{j\phi_v} / \sqrt{2}$$

$$I_{\text{rms}} = I_m e^{j\phi_i} / \sqrt{2}$$

Complex Power

$$S = \frac{1}{2} \mathbf{V} \mathbf{I}^* = V_{\text{rms}} \mathbf{I}_{\text{rms}}^* = P + jQ$$

Real Average Power

$$P = \Re \{S\} \text{ [W]}$$

$$= V_{\text{rms}} I_{\text{rms}} \cos(\phi_v - \phi_i)$$

$$= I_{\text{rms}}^2 R$$

Apparent Power

$$S = |S| = \sqrt{P^2 + Q^2}$$

$$= V_{\text{rms}} I_{\text{rms}}$$

$$= I_{\text{rms}}^2 |Z|$$

Reactive Power

$$Q = \Im \{S\} \text{ [VAR]}$$

$$= V_{\text{rms}} I_{\text{rms}} \sin(\phi_v - \phi_i)$$

$$= I_{\text{rms}}^2 X$$

Power Factor

$$pf = \frac{P}{S}$$

$$= \cos(\phi_v - \phi_i)$$

$$= \cos \phi_z$$

$$S = S e^{j\phi_s}$$

$$\phi_s = \phi_v - \phi_i = \phi_z$$



- Maximum average power transfer

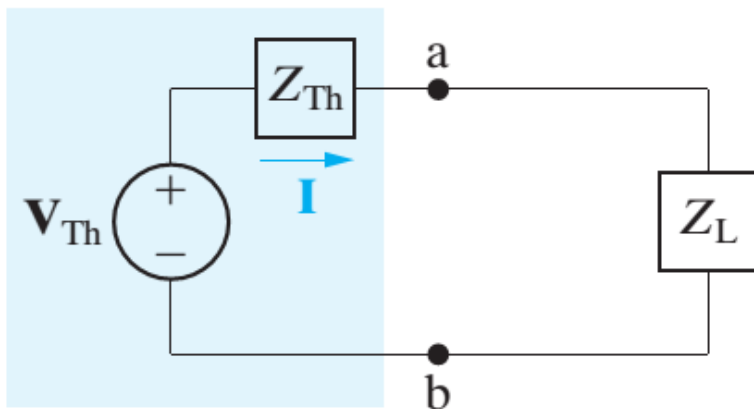

For Self-Study

- Power factor correction

