



Lecture 8

- Sinusoidal Steady-State Analysis



Outline

- Kirchhoff's laws in phasor domain
- Generalized impedance
- General AC phasor analysis
- Phasor diagram



Kirchhoff's Laws in the Phasor Domain

- Let v_1, v_2, \dots, v_n be the voltages around a closed loop. Then according to KVL

$$v_1 + v_2 + \dots + v_n = 0$$

$$\mathbf{V}_1 + \mathbf{V}_2 + \dots + \mathbf{V}_n = 0$$

Similarly, KCL holds for phasors:

$$i_1 + i_2 + \dots + i_n = 0$$

$$\mathbf{I}_1 + \mathbf{I}_2 + \dots + \mathbf{I}_n = 0,$$



Proof

If

$$v_1 + v_2 + \cdots + v_n = 0$$

where v_i are sinusoidal voltages of the same frequency, then

$$\mathbf{V}_1 + \mathbf{V}_2 + \cdots + \mathbf{V}_n = 0$$

Proof:

$$v_1 + v_2 + \cdots + v_n = 0$$



$$V_{m1} \cos(\omega t + \theta_1) + V_{m2} \cos(\omega t + \theta_2) + \cdots + V_{mn} \cos(\omega t + \theta_n) = 0$$



$$\operatorname{Re}(V_{m1} e^{j\theta_1} \cdot e^{j\omega t}) + \cdots + \operatorname{Re}(V_{mn} e^{j\theta_n} \cdot e^{j\omega t}) = 0$$



$$\operatorname{Re} \left((\mathbf{V}_1 + \cdots + \mathbf{V}_n) \cdot e^{j\omega t} \right) = 0 \text{ Where } \mathbf{V}_k = V_{mk} e^{j\theta_k}$$



$$\mathbf{V}_1 + \mathbf{V}_2 + \cdots + \mathbf{V}_n = 0$$



Outline

- Kirchhoff's laws in phasor domain
- Generalized impedance
- General AC phasor analysis
- Phasor diagram



Impedance and Admittance

Resistor	$Z = R$	$Y = 1/R$
Inductor	$Z = j\omega L$	$Y = 1/j\omega L$
Capacitor	$Z = 1/j\omega C$	$Y = j\omega C$

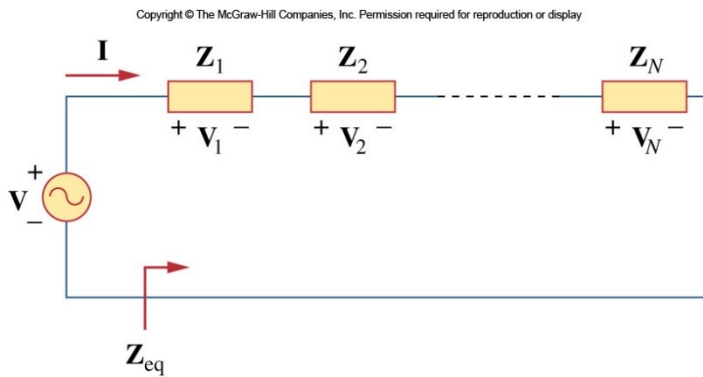

Series Impedance

- In phasor domain, combinations of *impedance* will follow the rules for **resistors**:

Copyright © The McGraw-Hill Companies, Inc. Permission required for reproduction or display

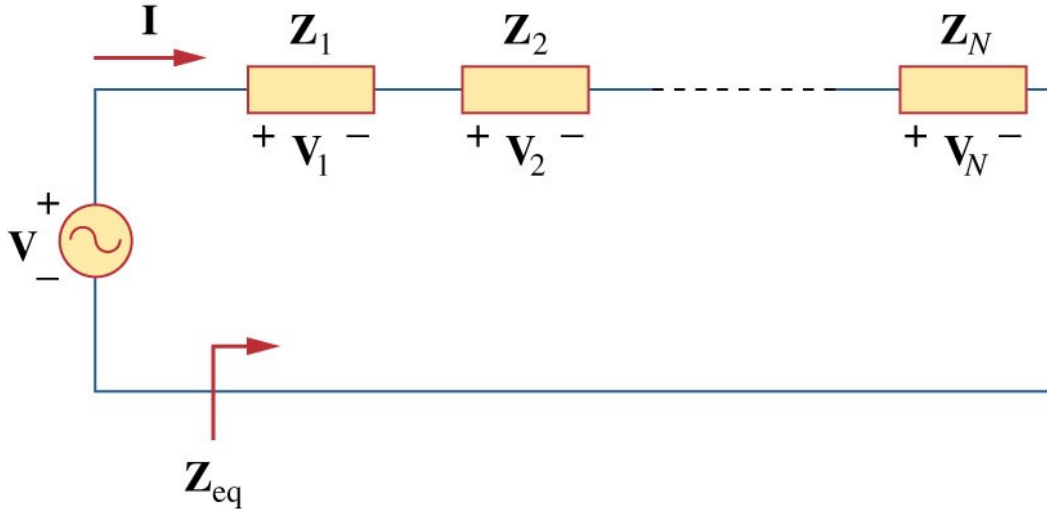

$$Z_{eq} = Z_1 + Z_2 + Z_3 + \dots$$

$$V_1 = \frac{Z_1}{Z_1 + \dots + Z_N} V$$

$$V_2 = \frac{Z_2}{Z_1 + \dots + Z_N} V$$



Series Impedance

$$\mathbf{Z}_{eq} = \mathbf{Z}_1 + \mathbf{Z}_2 + \mathbf{Z}_3$$

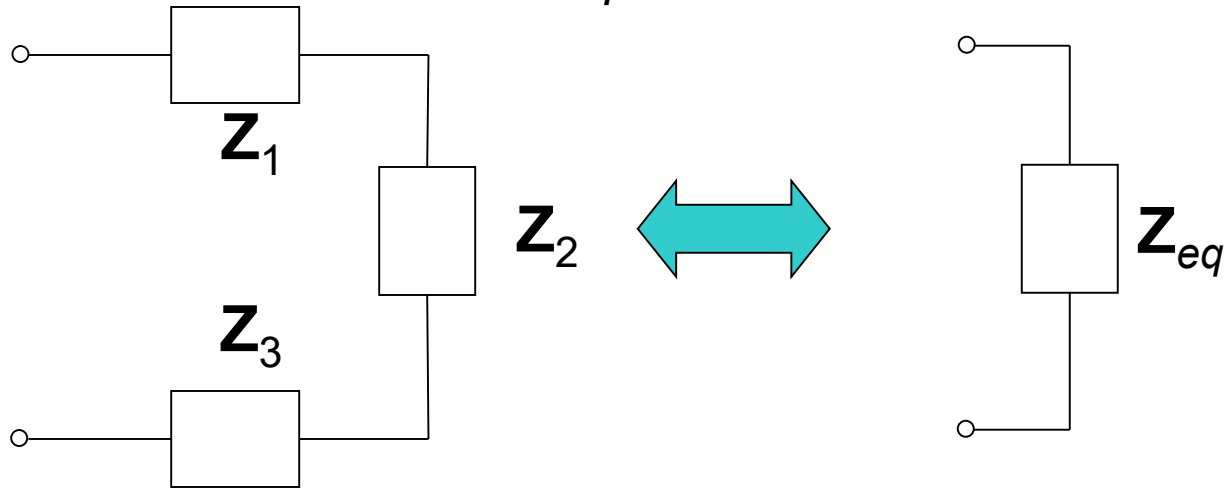

For example:

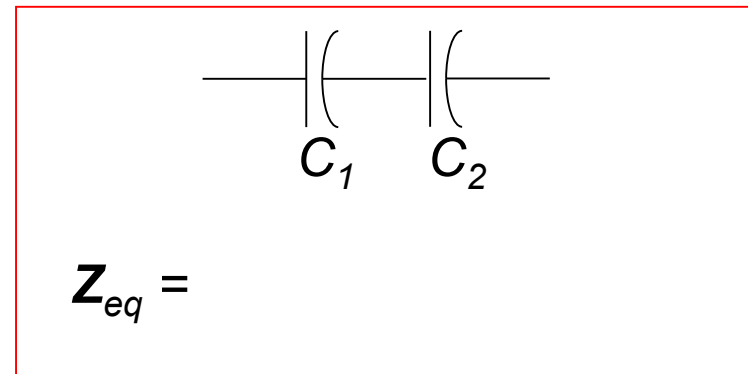
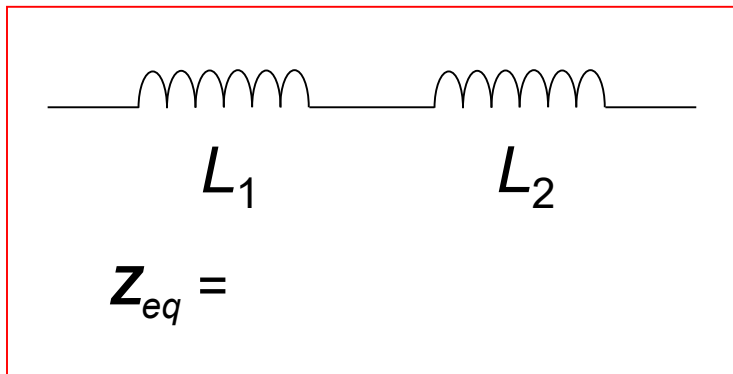



Impedance combination for RLC Circuit

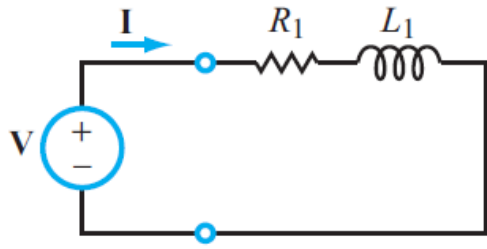

(a) RL

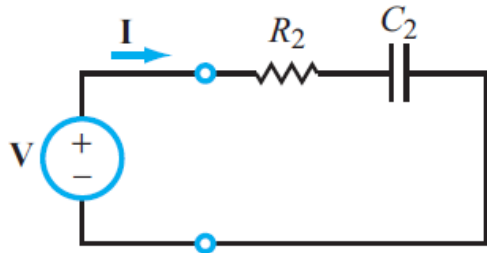
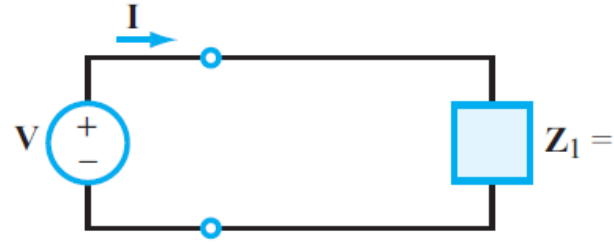

(b) RC

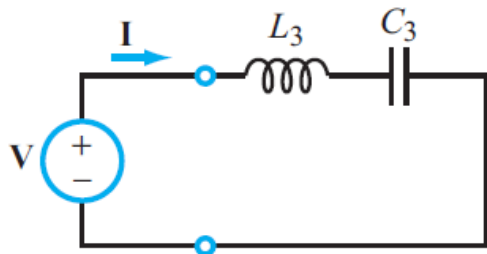

(c) LC

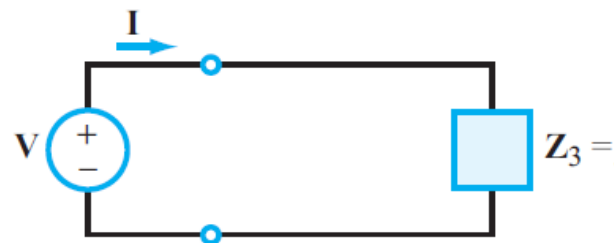

Parallel Combination

- Likewise, elements in parallel will combine in the same fashion as resistors in parallel:

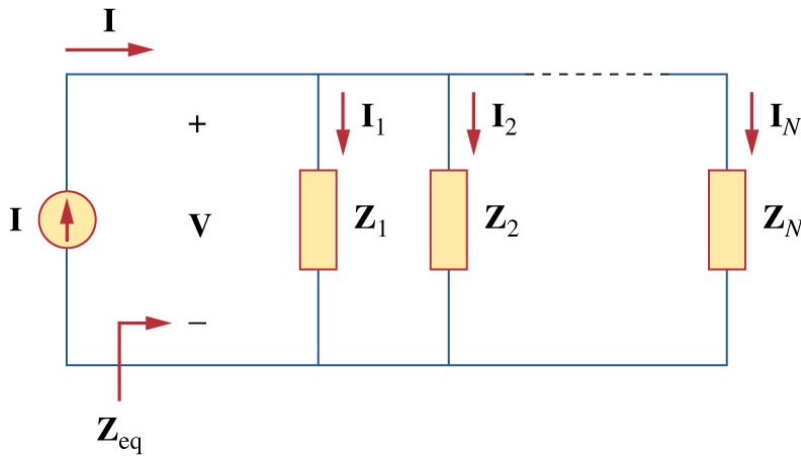

$$\frac{1}{Z_{eq}} = \frac{1}{Z_1} + \frac{1}{Z_2} + \frac{1}{Z_3} + \dots + \frac{1}{Z_N}$$

$$Y_{eq} = Y_1 + Y_2 + Y_3 + \dots$$

$$I_1 = \frac{Y_1}{Y_1 + \dots + Y_N} I$$

$$I_2 = \frac{Y_2}{Y_1 + \dots + Y_N} I$$

.....



Parallel Impedance

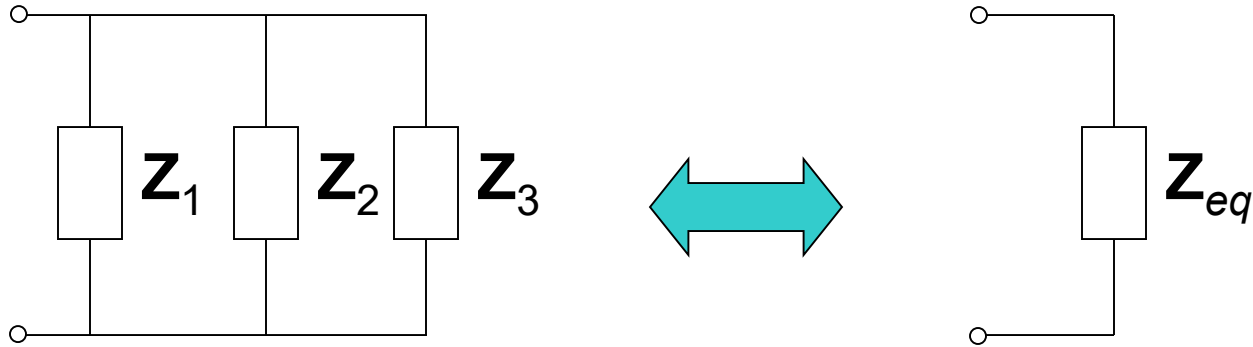

For example:
$$1/\mathbf{Z}_{eq} = 1/\mathbf{Z}_1 + 1/\mathbf{Z}_2 + 1/\mathbf{Z}_3$$

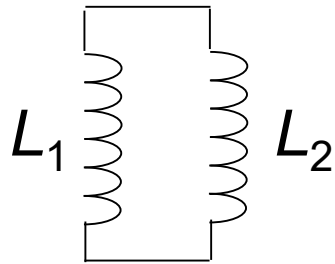

$$\mathbf{Z}_{eq} = j\omega \frac{L_1 L_2}{(L_1 + L_2)}$$

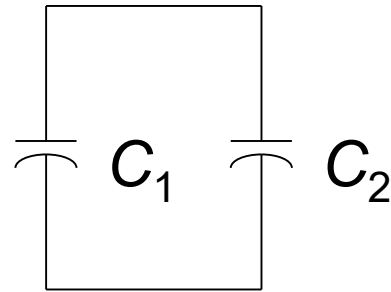

$$\mathbf{Z}_{eq} = \frac{1}{j\omega(C_1 + C_2)}$$



Exercise

- Find the input impedance of the circuit below. $\omega = 50$ rad/s.

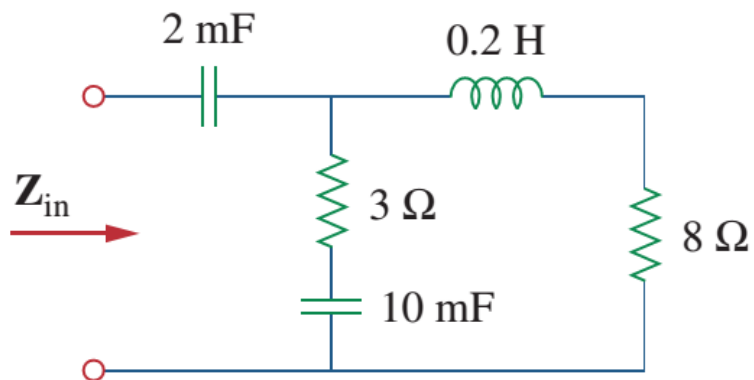



Delta-Wye Transformation in Phasor Domain

Copyright © The McGraw-Hill Companies, Inc. Permission required for reproduction or display

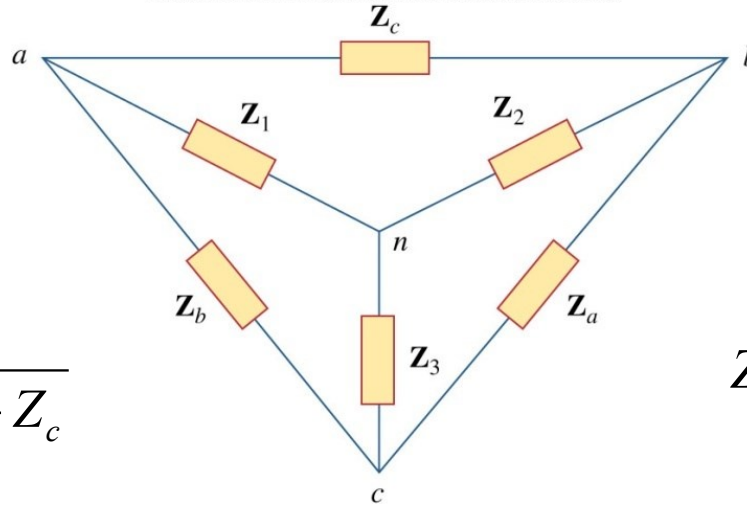

$$Z_1 = \frac{Z_b Z_c}{Z_a + Z_b + Z_c}$$

$$Z_2 = \frac{Z_c Z_a}{Z_a + Z_b + Z_c}$$

$$Z_3 = \frac{Z_a Z_b}{Z_a + Z_b + Z_c}$$

$$Z_a = \frac{Z_1 Z_2 + Z_2 Z_3 + Z_3 Z_1}{Z_1}$$

$$Z_b = \frac{Z_1 Z_2 + Z_2 Z_3 + Z_3 Z_1}{Z_2}$$

$$Z_c = \frac{Z_1 Z_2 + Z_2 Z_3 + Z_3 Z_1}{Z_3}$$



Impedance and Admittance

Resistor	$\mathbf{Z} = R$	$\mathbf{Y} = 1/R$
Inductor	$\mathbf{Z} = j\omega L$	$\mathbf{Y} = 1/j\omega L$
Capacitor	$\mathbf{Z} = 1/j\omega C$	$\mathbf{Y} = j\omega C$

Impedance is
voltage/current

$$\mathbf{Z} = R + jX$$

R = resistance = $\text{Re}(\mathbf{Z})$

X = reactance = $\text{Im}(\mathbf{Z})$

Admittance is
current/voltage

$$\mathbf{Y} = \frac{1}{\mathbf{Z}} = G + jB$$

G = conductance = $\text{Re}(\mathbf{Y})$

B = susceptance = $\text{Im}(\mathbf{Y})$



Outline

- Kirchhoff's laws in phasor domain
- Generalized impedance
- General AC phasor analysis
 - Nodal/mesh analysis
 - Superposition
 - Source transformation/Thevenin/Norton
- Phasor diagram



AC Phasor Analysis General Procedure

Step 1: Adopt cosine reference

$$v_s(t) = 12 \sin(\omega t - 45^\circ)$$

$$= 12 \cos(\omega t - 45^\circ - 90^\circ) = 12 \cos(\omega t - 135^\circ) \text{ V.}$$

$$\mathbf{V}_s = 12e^{-j135^\circ} \text{ V.}$$

Step 2: Transform circuit to phasor domain

Step 3: Cast KCL and/or KVL equations in phasor domain

$$\mathbf{Z}_R \mathbf{I} + \mathbf{Z}_C \mathbf{I} = \mathbf{V}_s,$$

which is equivalent to

$$\left(R + \frac{1}{j\omega C} \right) \mathbf{I} = 12e^{-j135^\circ}.$$

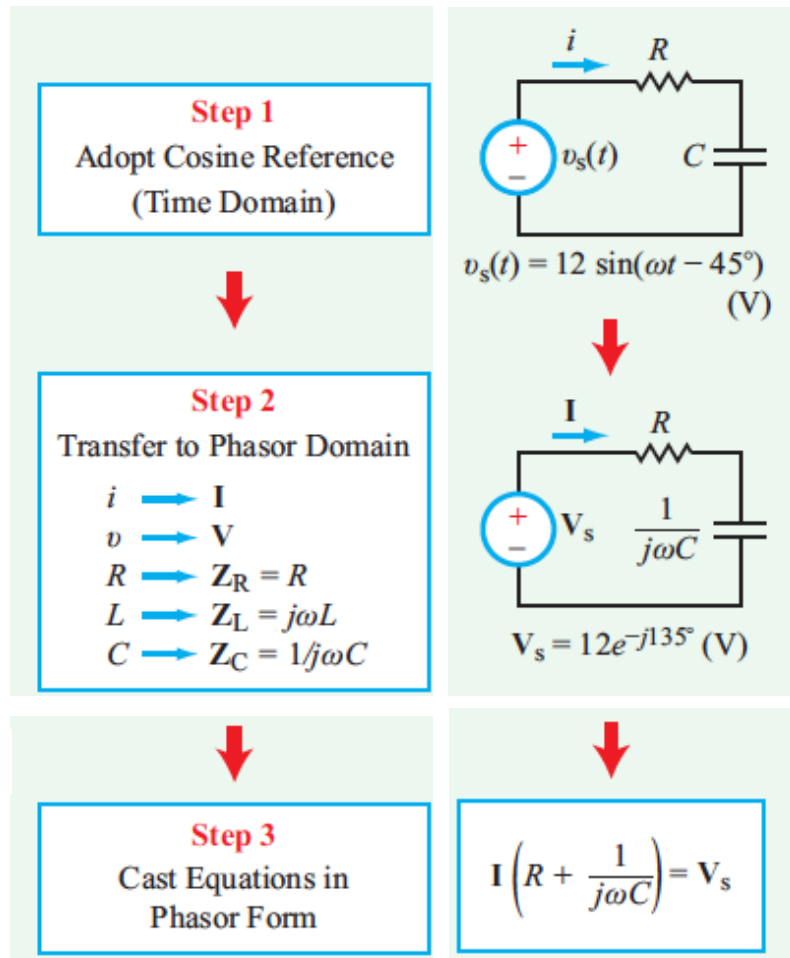



AC Phasor Analysis General Procedure

Step 4: Solve for unknown variable

$$\mathbf{I} = \frac{12e^{-j135^\circ}}{R + \frac{1}{j\omega C}} = \frac{j12\omega C e^{-j135^\circ}}{1 + j\omega RC}$$

Using the specified values, namely $R = \sqrt{3} \text{ k}\Omega$, $C = 1 \text{ }\mu\text{F}$, and $\omega = 10^3 \text{ rad/s}$,

$$\mathbf{I} = \frac{j12 \times 10^3 \times 10^{-6} e^{-j135^\circ}}{1 + j10^3 \times \sqrt{3} \times 10^3 \times 10^{-6}} = \frac{j12e^{-j135^\circ}}{1 + j\sqrt{3}} \text{ mA.}$$

$$\mathbf{I} = \frac{12e^{-j135^\circ} \cdot e^{j90^\circ}}{2e^{j60^\circ}} = 6e^{j(-135^\circ+90^\circ-60^\circ)} = 6e^{-j105^\circ} \text{ mA.}$$

Step 5: Transform solution back to time domain

To return to the time domain, we apply the fundamental relation between a sinusoidal function and its phasor counterpart, namely

$$i(t) = \Re\{Ie^{j\omega t}\} = \Re\{6e^{-j105^\circ} e^{j\omega t}\} = 6 \cos(\omega t - 105^\circ) \text{ mA.}$$

Step 1

Adopt Cosine Reference
(Time Domain)

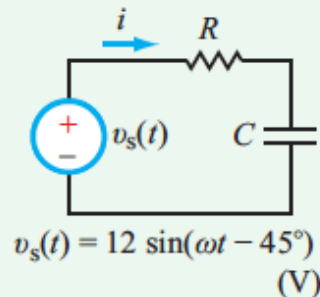

Step 2

Transfer to Phasor Domain

- $i \rightarrow \mathbf{I}$
- $v \rightarrow \mathbf{V}$
- $R \rightarrow \mathbf{Z}_R = R$
- $L \rightarrow \mathbf{Z}_L = j\omega L$
- $C \rightarrow \mathbf{Z}_C = 1/j\omega C$

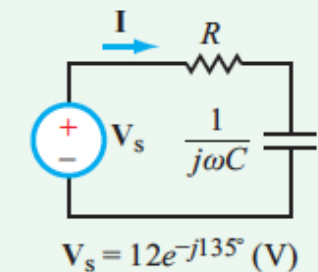

Step 3

Cast Equations in
Phasor Form

$$\mathbf{I} \left(R + \frac{1}{j\omega C} \right) = \mathbf{V}_s$$

Step 4

Solve for Unknown Variable
(Phasor Domain)

$$\mathbf{I} = \frac{\mathbf{V}_s}{R + \frac{1}{j\omega C}}$$

Step 5

Transform Solution
Back to Time Domain

$$i(t) = \Re\{Ie^{j\omega t}\} = 6 \cos(\omega t - 105^\circ) \text{ (mA)}$$



Nodal Analysis

- Example---Find i_x

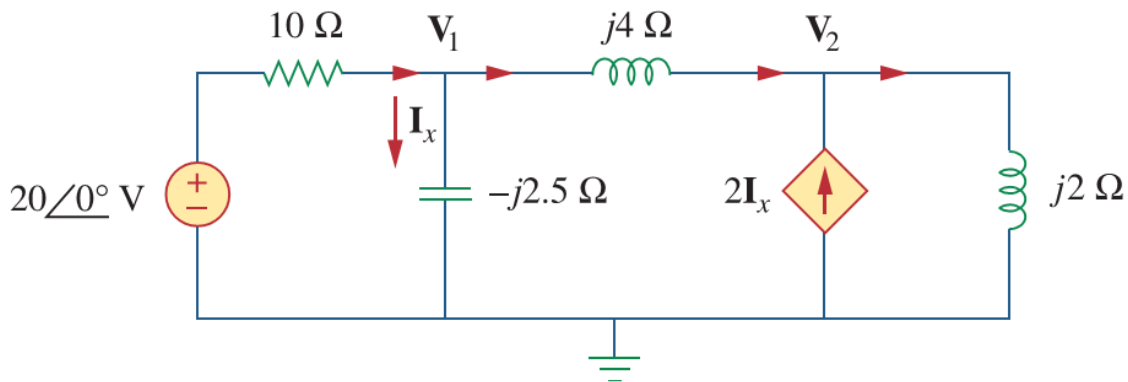
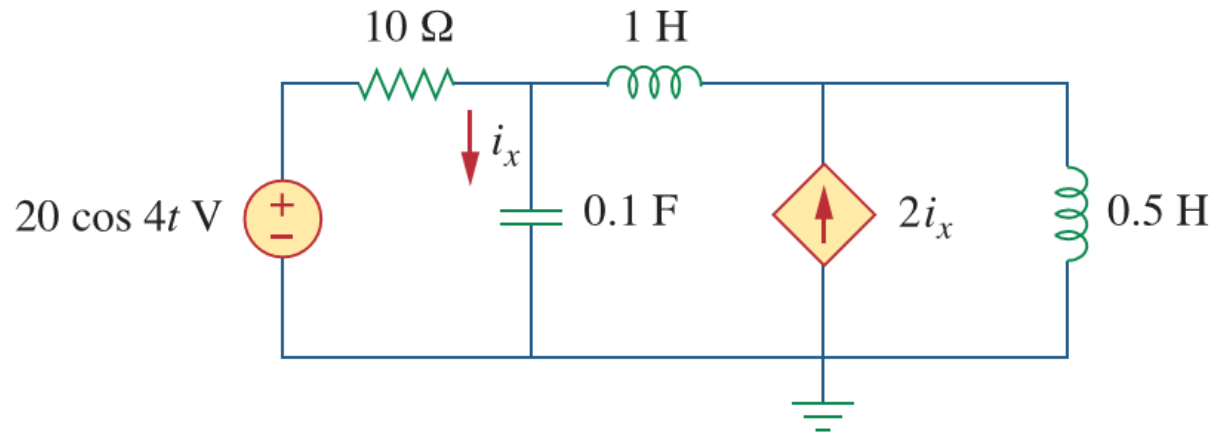

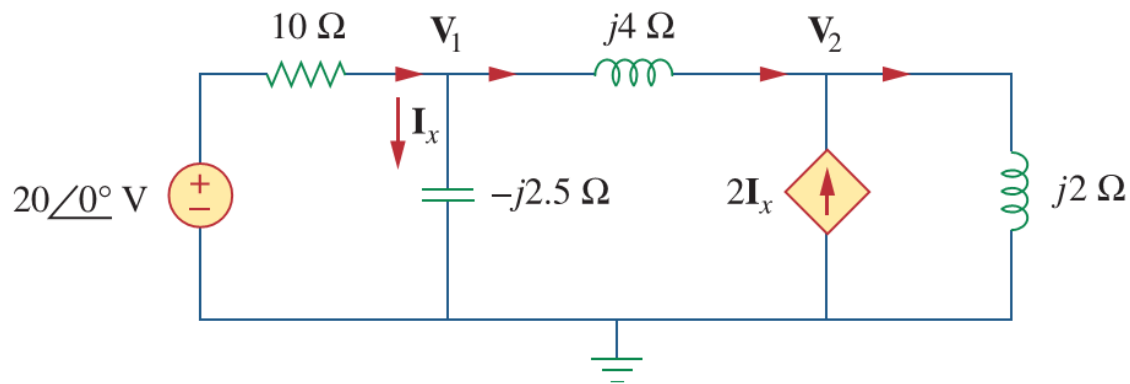

$$\frac{20 - \mathbf{V}_1}{10} = \frac{\mathbf{V}_1}{-j2.5} + \frac{\mathbf{V}_1 - \mathbf{V}_2}{j4}$$

$$2\mathbf{I}_x + \frac{\mathbf{V}_1 - \mathbf{V}_2}{j4} = \frac{\mathbf{V}_2}{j2}$$



Mesh Analysis

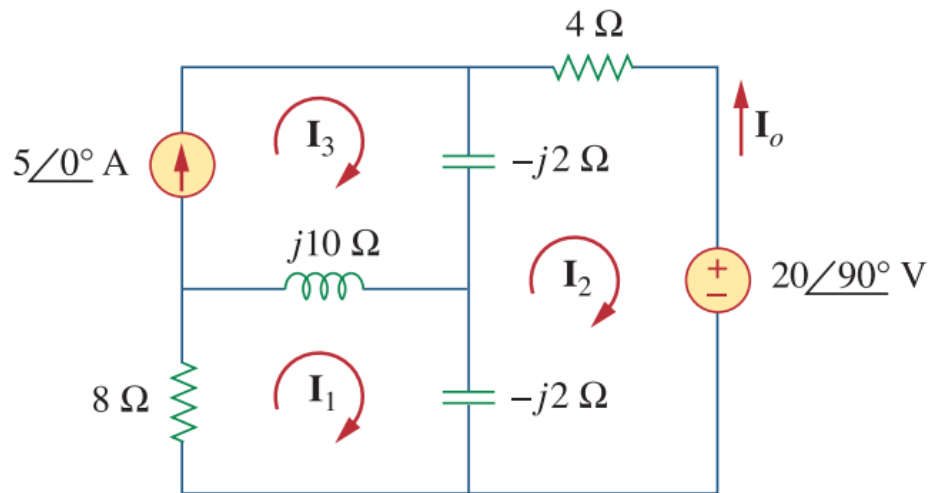



Mesh Analysis

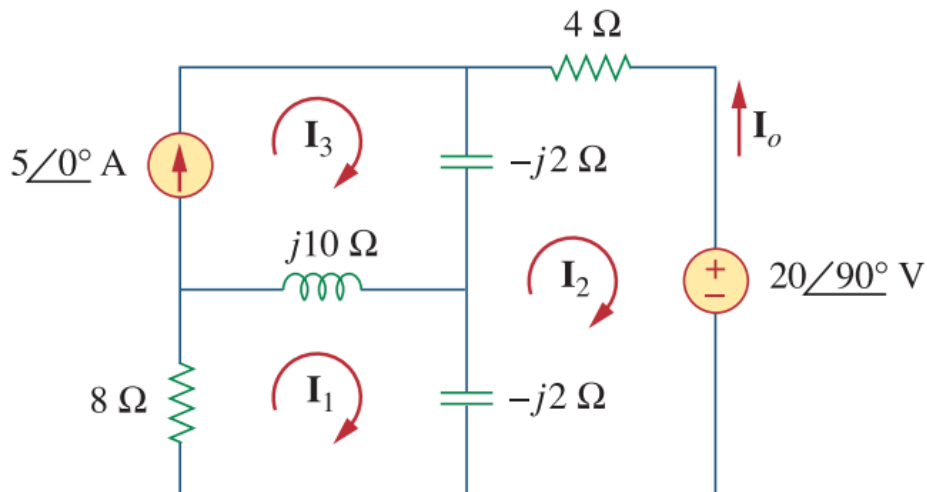

Applying KVL to mesh 1, we obtain

$$(8 + j10 - j2)\mathbf{I}_1 - (-j2)\mathbf{I}_2 - j10\mathbf{I}_3 = 0 \quad (10.3.1)$$

For mesh 2,

$$(4 - j2 - j2)\mathbf{I}_2 - (-j2)\mathbf{I}_1 - (-j2)\mathbf{I}_3 + 20\angle 90^\circ = 0 \quad (10.3.2)$$

For mesh 3, $\mathbf{I}_3 = 5$. Substituting this in Eqs. (10.3.1) and (10.3.2), we get

$$(8 + j8)\mathbf{I}_1 + j2\mathbf{I}_2 = j50 \quad (10.3.3)$$

$$j2\mathbf{I}_1 + (4 - j4)\mathbf{I}_2 = -j20 - j10 \quad (10.3.4)$$



Superposition-Example

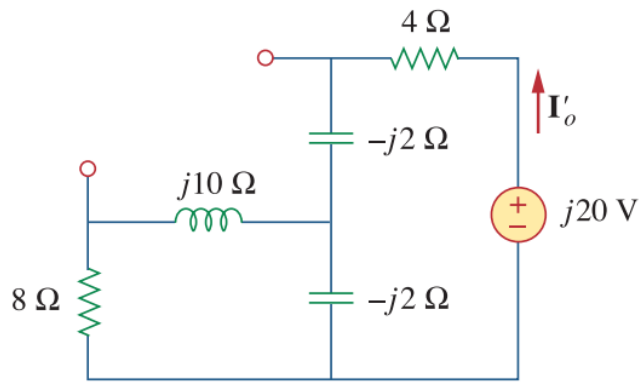
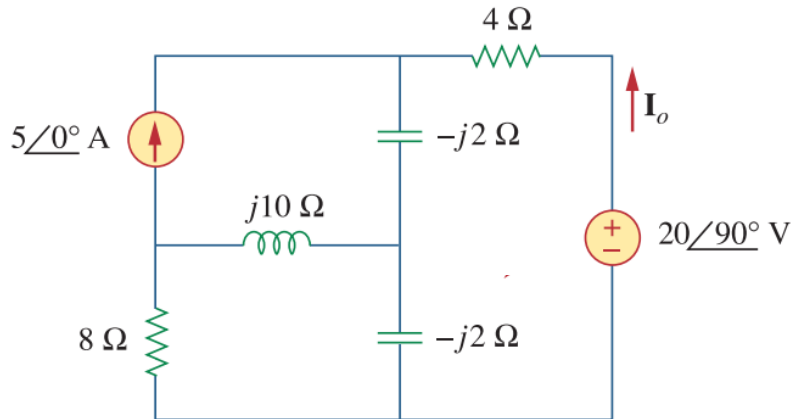

(a)

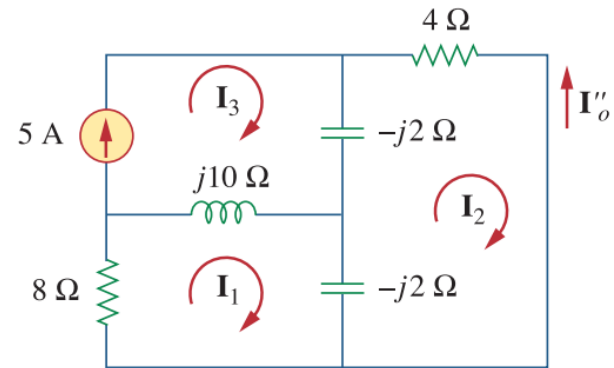

(b)



Superposition-Example 2



Thevenin Equivalent

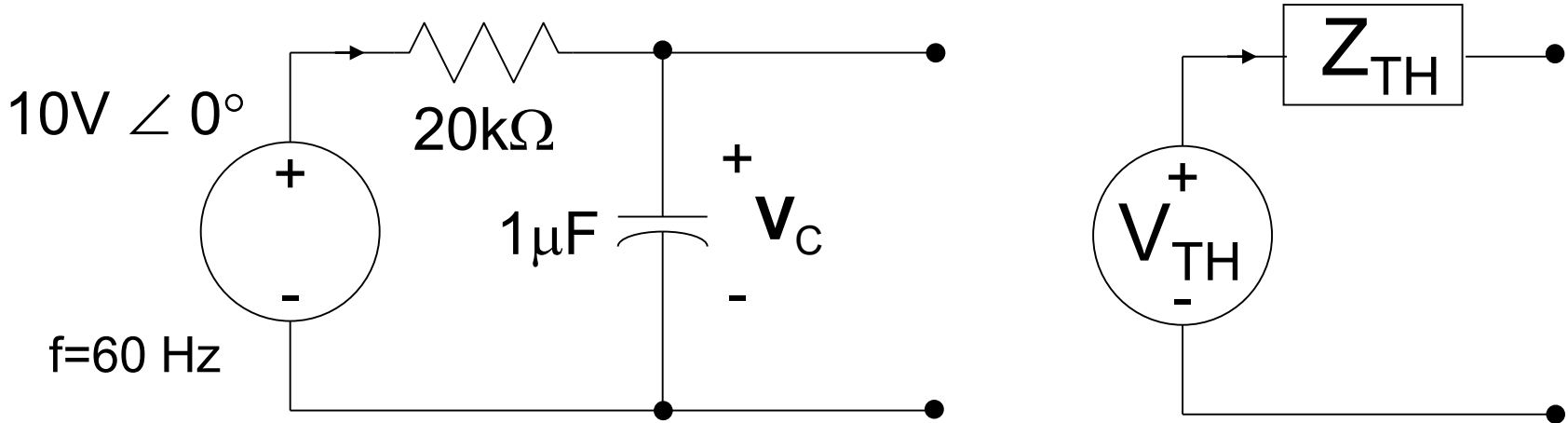

$$\mathbf{Z}_R = R = 20\text{k}\Omega = 20\text{k}\Omega \angle 0^\circ$$

$$\mathbf{Z}_C = 1/j(2\pi f \times 1\mu\text{F}) = 2.65\text{k}\Omega \angle -90^\circ$$

$$\mathbf{V}_{TH} = \mathbf{V}_{OC} = 10\text{V} \angle 0^\circ \left(\frac{2.65\text{k}\Omega \angle -90^\circ}{2.65\text{k}\Omega \angle -90^\circ + 20\text{k}\Omega \angle 0^\circ} \right) = 1.31 \angle -82.4$$

$$\mathbf{Z}_{TH} = \mathbf{Z}_R \parallel \mathbf{Z}_C = \left(\frac{20\text{k}\Omega \angle 0^\circ \cdot 2.65\text{k}\Omega \angle -90^\circ}{2.65\text{k}\Omega \angle -90^\circ + 20\text{k}\Omega \angle 0^\circ} \right) = 2.62 \angle -82.4$$



Source transformation/Norton

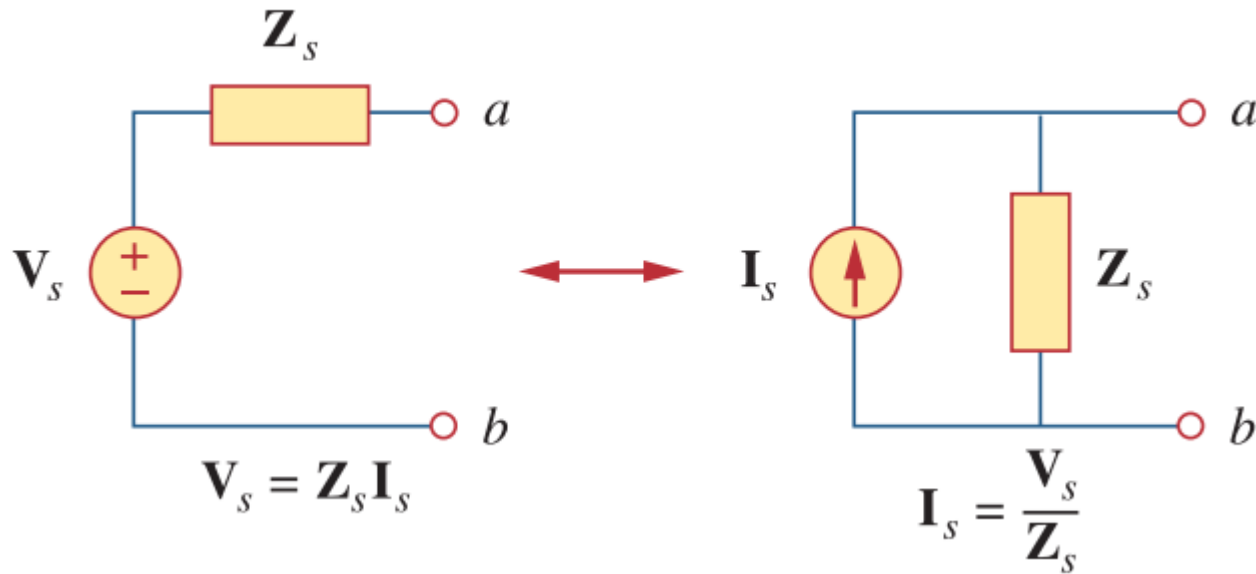

$$V_s = Z_s I_s \quad \Leftrightarrow \quad I_s = \frac{V_s}{Z_s}$$



AC Op Amp Circuits

Question 1: Are op amps used in ac circuits?

Answer 1: Yes.

Question 2: Is the ideal op-amp model applicable to ac circuits?

Answer 2: The ideal op-amp model is based on the assumption that the open-loop gain A is very large ($> 10^4$), which is true at dc and low frequencies, but not necessarily so at high frequencies. The range of frequencies over which A is large depends on the specific op-amp design.

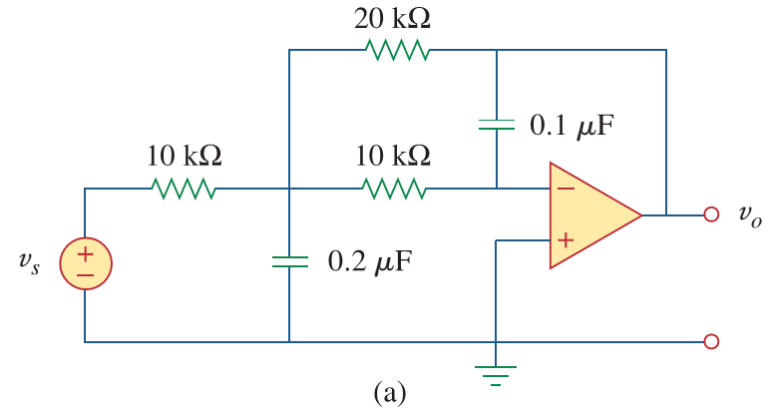



Example – find v_o

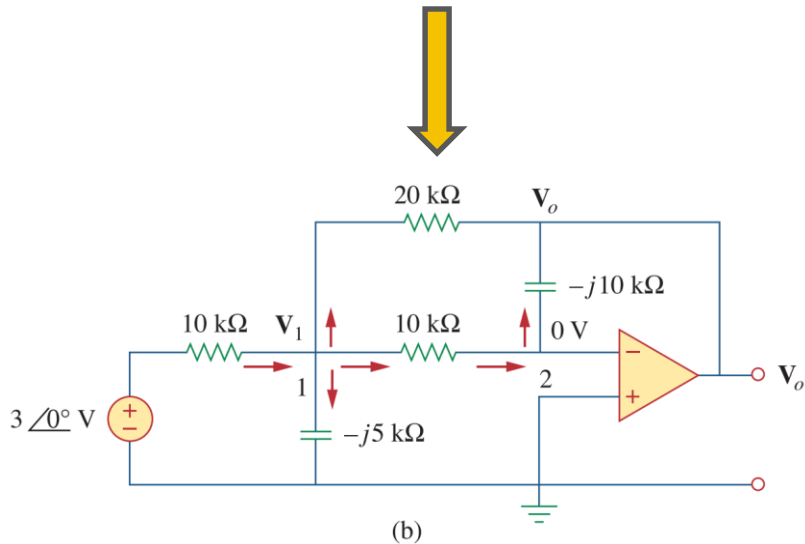
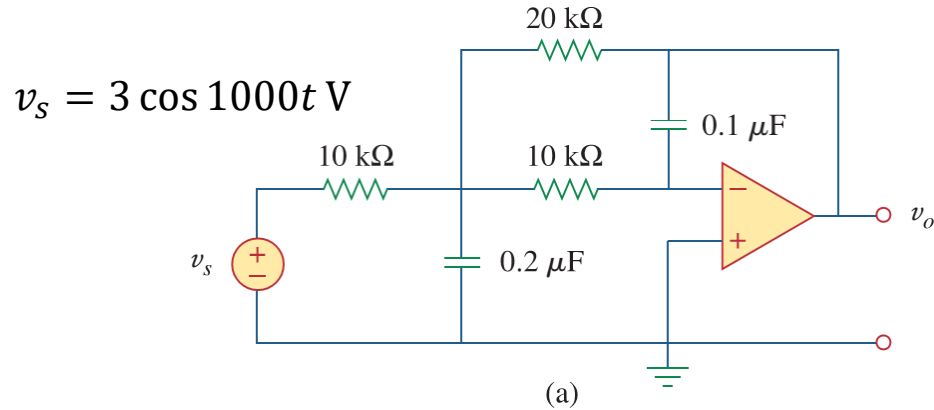



Outline

- Kirchhoff's laws in phasor domain
- Generalized impedance
- General AC phasor analysis
- Phasor diagram



Phasor Diagrams

Capacitor

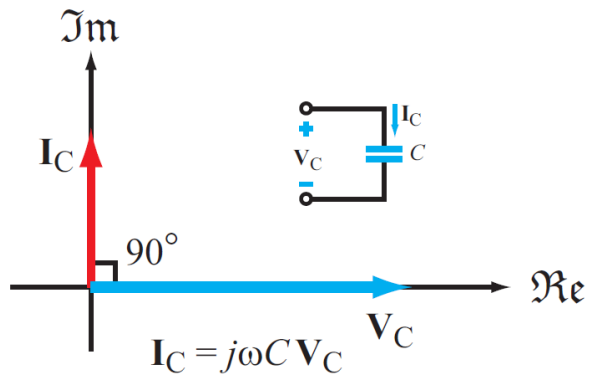

Inductor

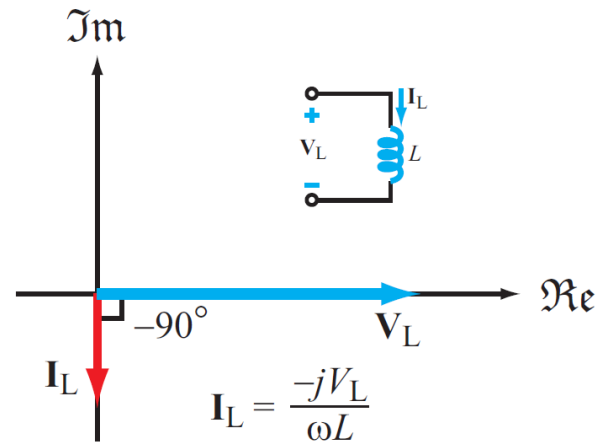

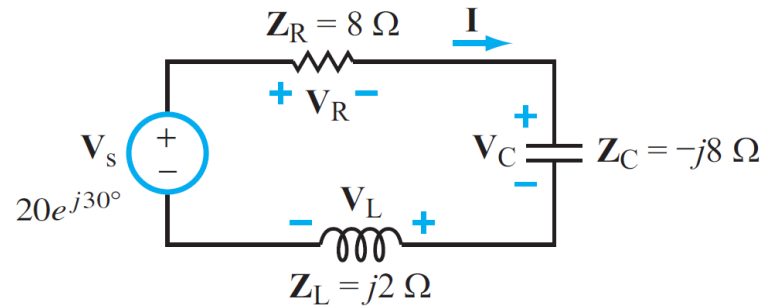

$$\mathbf{I} = \frac{\mathbf{V}_s}{R + j\omega L - \frac{j}{\omega C}} = \frac{20e^{j30^\circ}}{8 + j2 - j8} = \frac{20e^{j30^\circ}}{8 - j6} = \frac{20e^{j30^\circ}}{10e^{-j36.87^\circ}} = 2e^{j66.87^\circ} \text{ A}$$

