



Lecture 6

- Second-Order Circuits



Second-Order Circuits

- **Two** energy storage elements
- **Analysis:** basically determine voltage or current as a function of time
- A second-order circuit is characterized by a second-order differential equation.

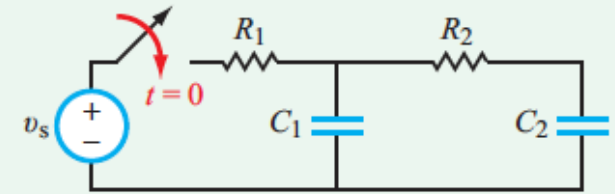

(a) 2 capacitors

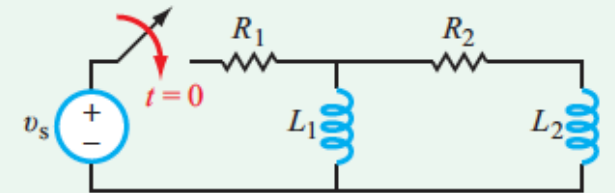

(b) 2 inductors

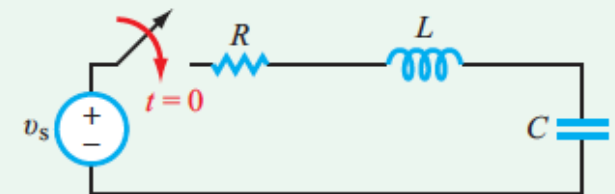

(c) Series RLC

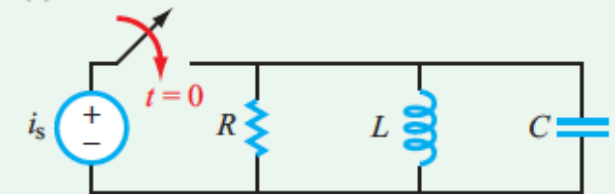

(d) Parallel RLC



Outline

- Natural Response Series/Parallel RLC circuit
Source-free
- Step Response of a Series/Parallel RLC Circuit
With Independent Source
- General 2nd-order circuits



Source-Free Series RLC Circuit

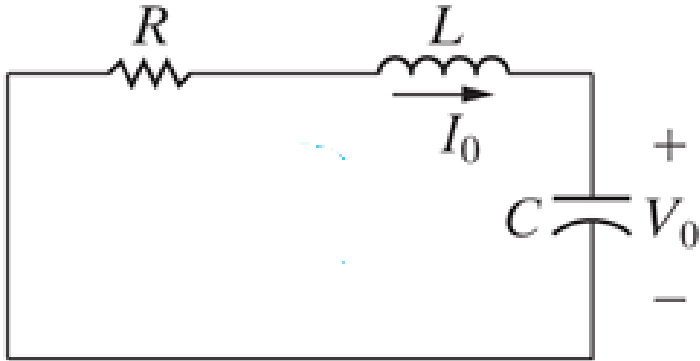





Source-Free Series RLC Circuit

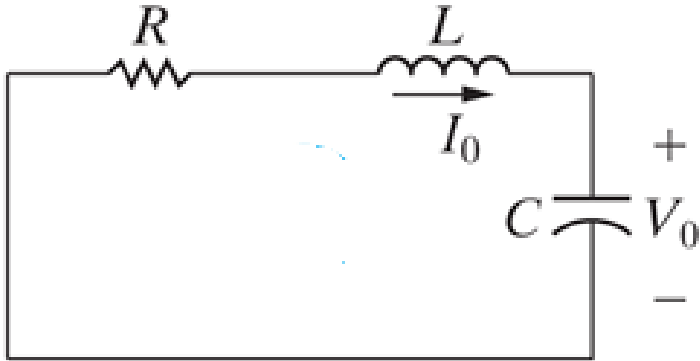

$$\frac{d^2v}{dt^2} + \frac{R}{L} \frac{dv}{dt} + \frac{1}{LC} v = 0$$

$$s^2 + \frac{R}{L}s + \frac{1}{LC} = 0$$

$$s = -\frac{R}{2L} \pm \sqrt{\left(\frac{R}{2L}\right)^2 - \frac{1}{LC}}$$



Example

- The switch has been closed for a long time. It is open at $t = 0$. Find
 - $v(0^+), i(0^+)$
 - $dv(0^+)/dt$
 - $di(0^+)/dt$

Copyright © The McGraw-Hill Companies, Inc. Permission required for reproduction or display

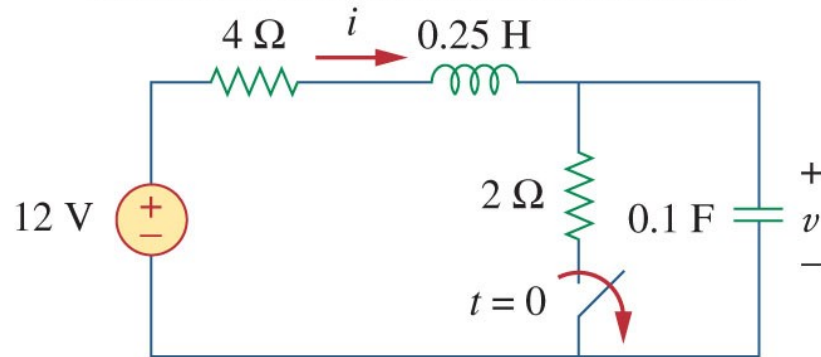

Copyright © The McGraw-Hill Companies, Inc. Permission required for reproduction or

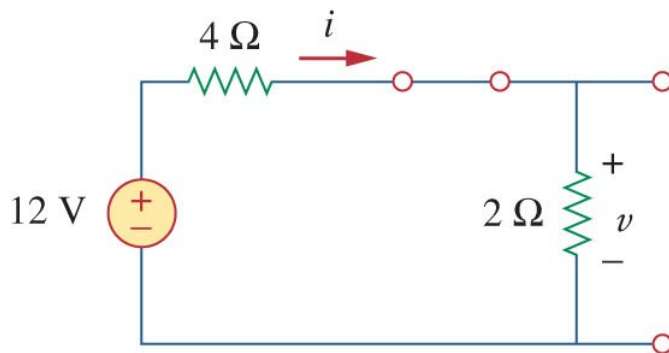

(a)

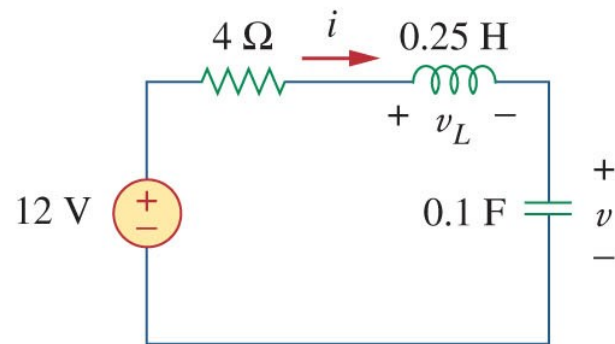

(b)





Exercise

- Assume the circuit has reached steady state at $t = 0^-$.

Find

- $v(0^+), dv(0^+)/dt$
- $i(0^+), di(0^+)/dt$

Copyright © The McGraw-Hill Companies, Inc. Permission required for reproduction or display

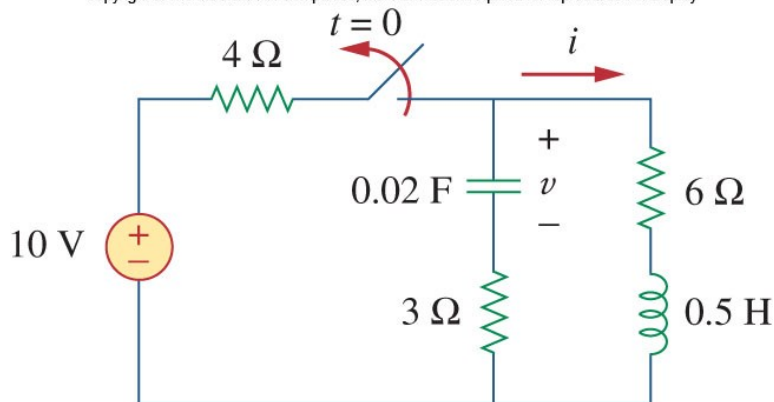



Case 1: Overdamped ($\alpha > \omega_0$)

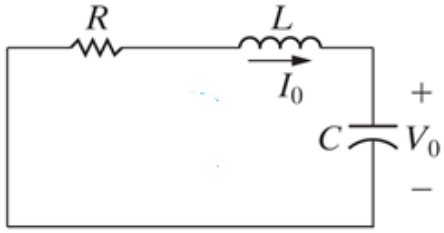

$$\frac{d^2 v}{dt^2} + \frac{R}{L} \frac{dv}{dt} + \frac{1}{LC} v = 0$$

$$s = -\frac{R}{2L} \pm \sqrt{\left(\frac{R}{2L}\right)^2 - \frac{1}{LC}}$$

$$\alpha = \frac{R}{2L} \quad \omega_0 = \frac{1}{\sqrt{LC}}$$

$$s_1 = -\alpha + \sqrt{\alpha^2 - \omega_0^2} \quad s_2 = -\alpha - \sqrt{\alpha^2 - \omega_0^2}$$

$$v(t) = A_1 e^{s_1 t} + A_2 e^{s_2 t}$$



An example

$$V_c = 2e^{-t} + 3e^{-t/2}$$

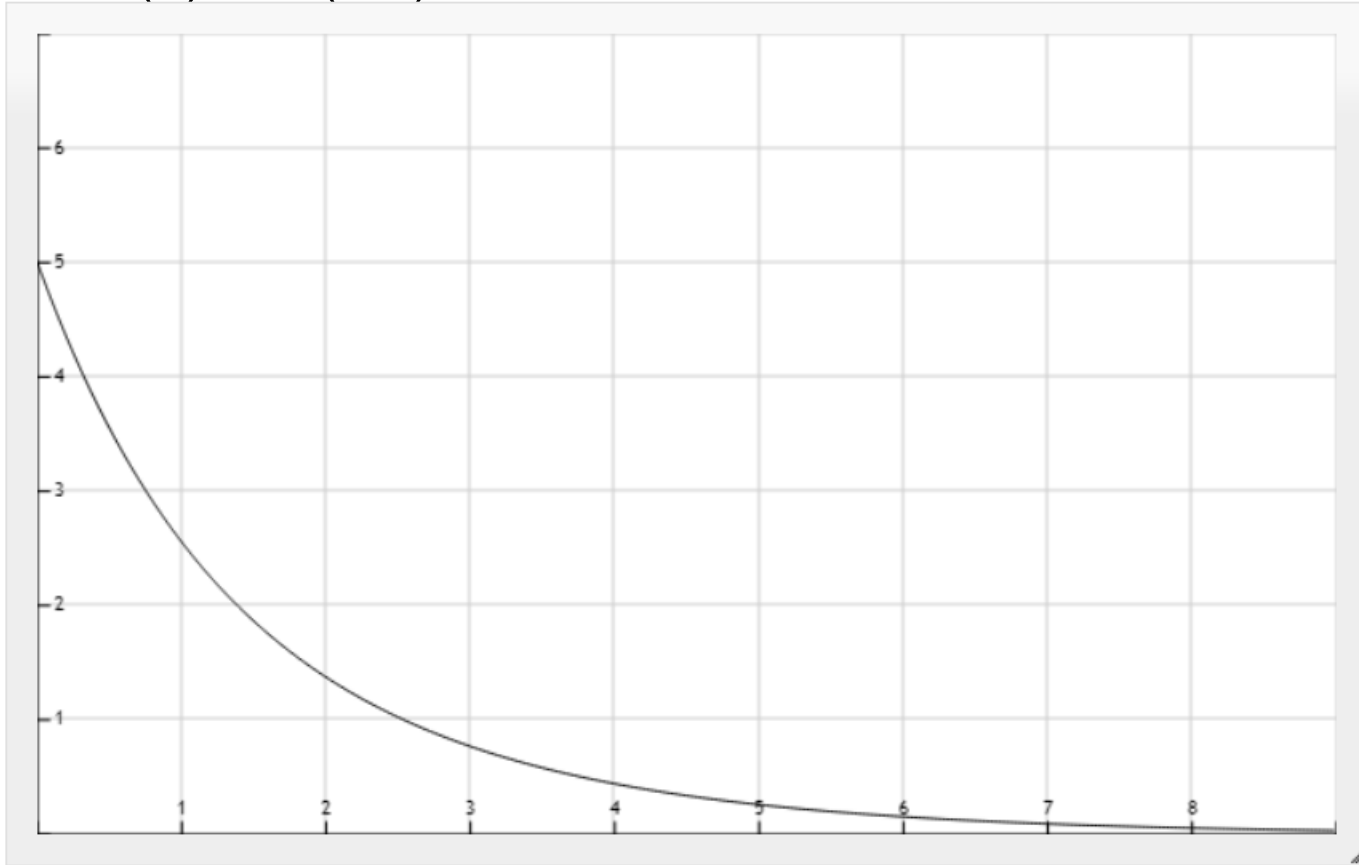



Case 2: Critically Damped ($\alpha = \omega_0$)

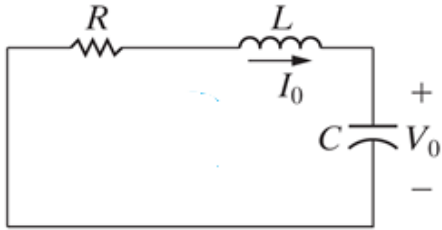

$$\frac{d^2 v}{dt^2} + \frac{R}{L} \frac{dv}{dt} + \frac{1}{LC} v = 0 \quad s = -\frac{R}{2L} \pm \sqrt{\left(\frac{R}{2L}\right)^2 - \frac{1}{LC}}$$

$$\alpha = \frac{R}{2L} \quad \omega_0 = \frac{1}{\sqrt{LC}}$$

$$s_1 = -\alpha + \sqrt{\alpha^2 - \omega_0^2} \quad s_2 = -\alpha - \sqrt{\alpha^2 - \omega_0^2}$$

$$s_1 = s_2 = -\alpha = -\frac{R}{2L}$$



Case 2: Critically Damped ($\alpha=\omega_0$)

$$v(t) = (A_1 t + A_2)e^{-\alpha t}$$



Case 3: Underdamped ($\alpha < \omega_0$)

$$\frac{d^2 v}{dt^2} + \frac{R}{L} \frac{dv}{dt} + \frac{1}{LC} v = 0$$

$$\alpha = \frac{R}{2L} \quad \omega_0 = \frac{1}{\sqrt{LC}}$$

$$s = -\alpha \pm \sqrt{\alpha^2 - \omega_0^2}$$

$$s_1 = -\alpha + \sqrt{\alpha^2 - \omega_0^2} = -\alpha + \sqrt{-(\omega_0^2 - \alpha^2)} = -\alpha + j\omega_d$$

$$s_2 = -\alpha - \sqrt{\alpha^2 - \omega_0^2} = -\alpha - \sqrt{-(\omega_0^2 - \alpha^2)} = -\alpha - j\omega_d$$

where $j = \sqrt{-1}$ and $\omega_d = \sqrt{\omega_0^2 - \alpha^2}$.

- ω_0 is often called the resonant frequency;
- ω_d is called the damping frequency.

The natural response

$$v(t) = A_1 e^{s_1 t} + A_2 e^{s_2 t}$$

becomes





The natural response

$$v(t) = A_1 e^{s_1 t} + A_2 e^{s_2 t}$$

becomes

$$v(t) = e^{-\alpha t} (B_1 \cos \omega_d t + B_2 \sin \omega_d t)$$

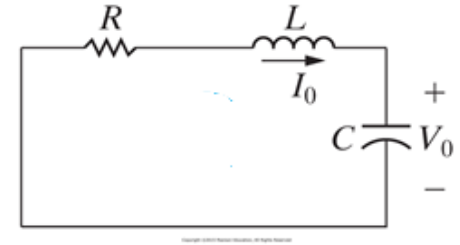

- Exponential $e^{-\alpha t}$ * Sine/Cosine term
 - Exponentially damped, time constant = $1/\alpha$
 - Oscillatory, period $T = \frac{2\pi}{\omega_d}$

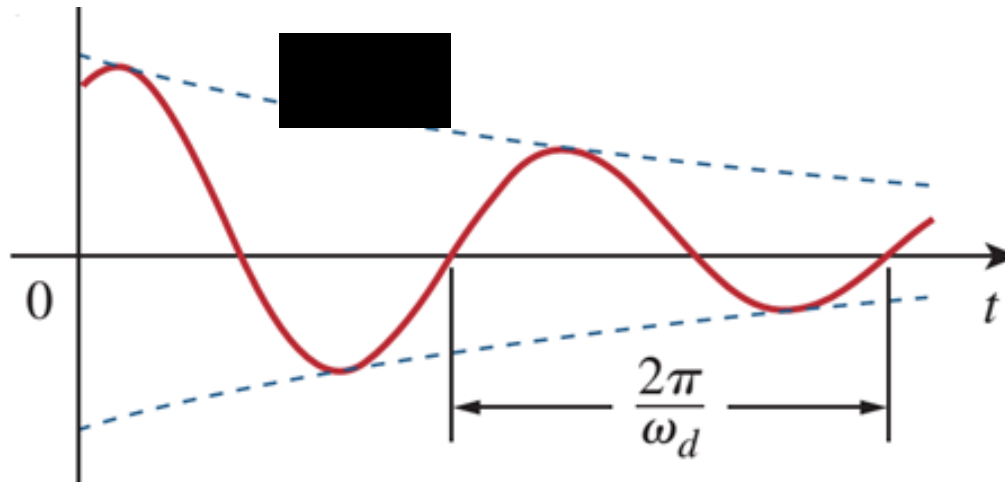



Example

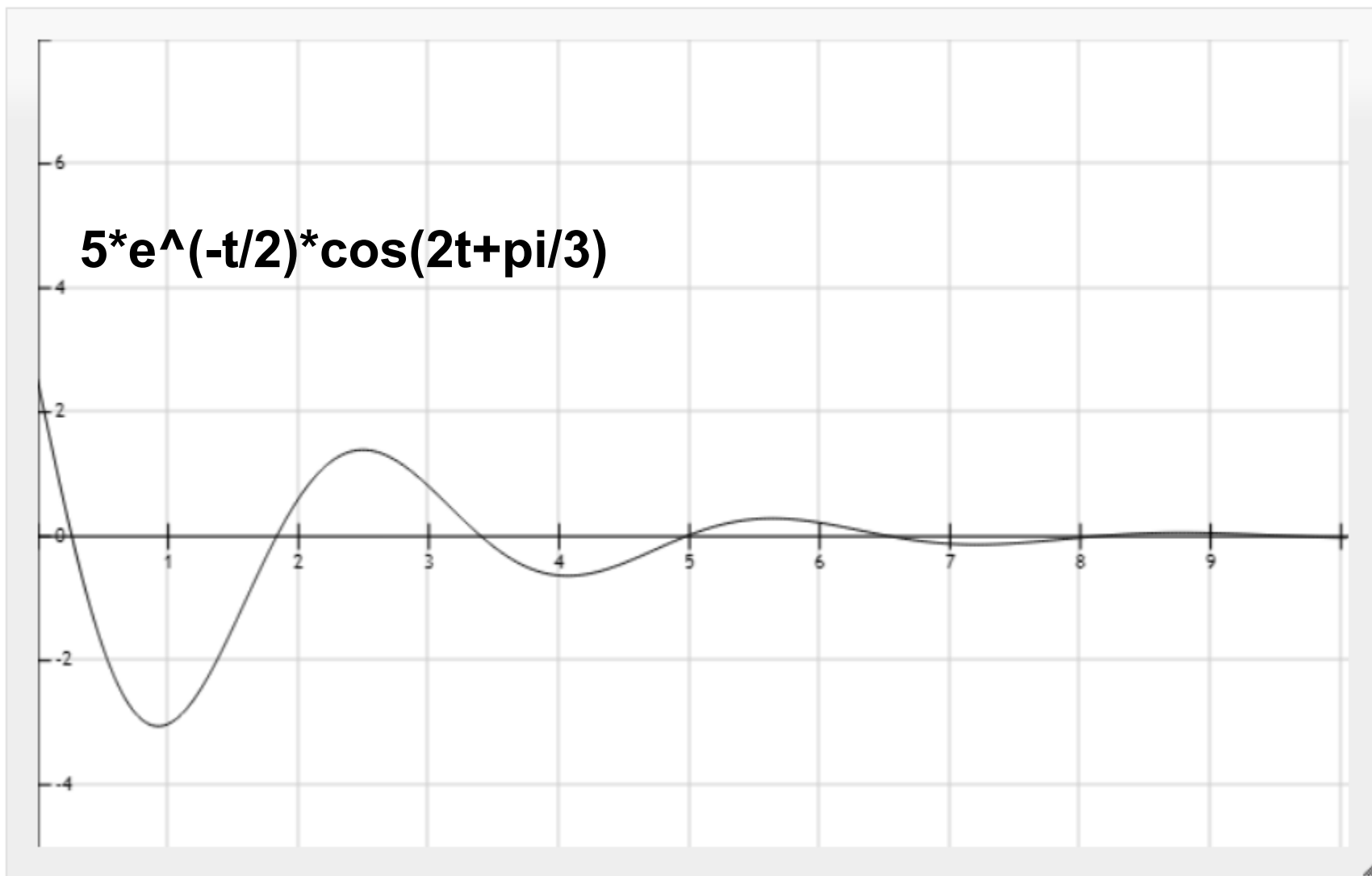

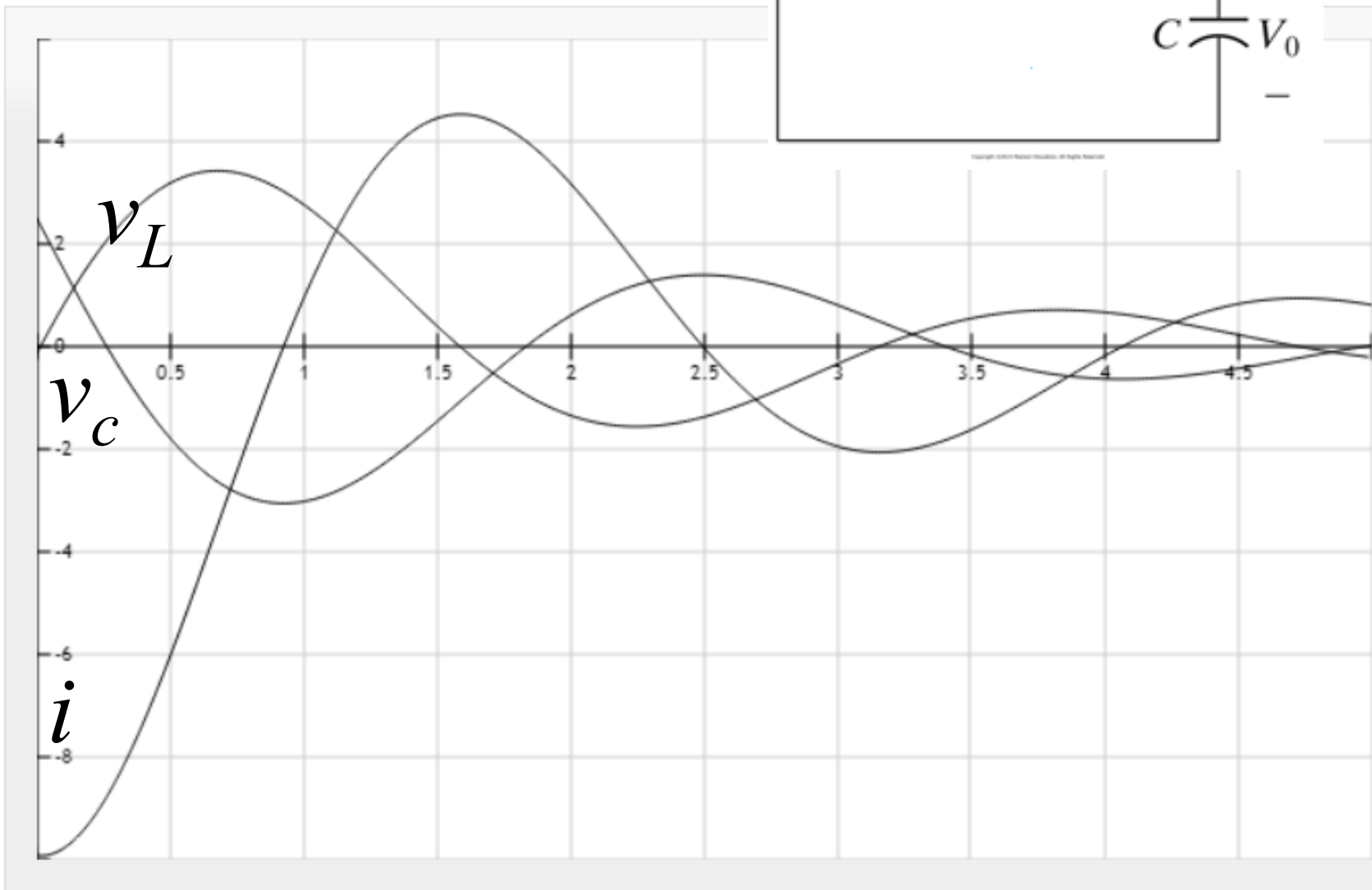
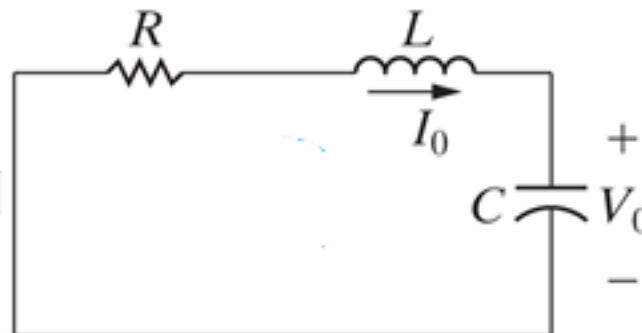



Properties of Series RLC Network - $v(t)$

- Behavior captured by damping
 - Gradual **loss** of the initial stored energy
 - α determines the rate of damping

$$\alpha = \frac{R}{2L} \quad \omega_0 = \frac{1}{\sqrt{LC}}$$

- ◆ $\alpha > \omega_0$, overdamped

$$v(t) = A_1 e^{s_1 t} + A_2 e^{s_2 t}$$

- ◆ $\alpha = \omega_0$, critically damped

$$v(t) = (A_1 t + A_2) e^{-\alpha t}$$

- ◆ $\alpha < \omega_0$, underdamped

$$v(t) = e^{-\alpha t} (B_1 \cos \omega_d t + B_2 \sin \omega_d t)$$

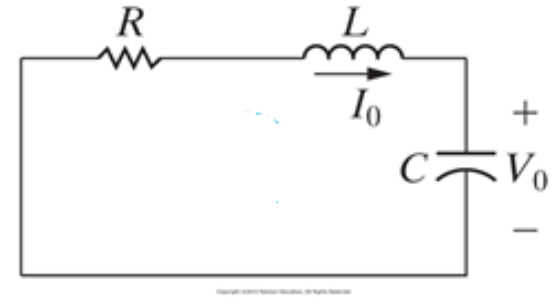



Example

- Find $v(t)$ in the circuit below. Assume the circuit has reached steady state at $t = 0^-$.

Copyright © The McGraw-Hill Companies, Inc. Permission required for reproduction or display

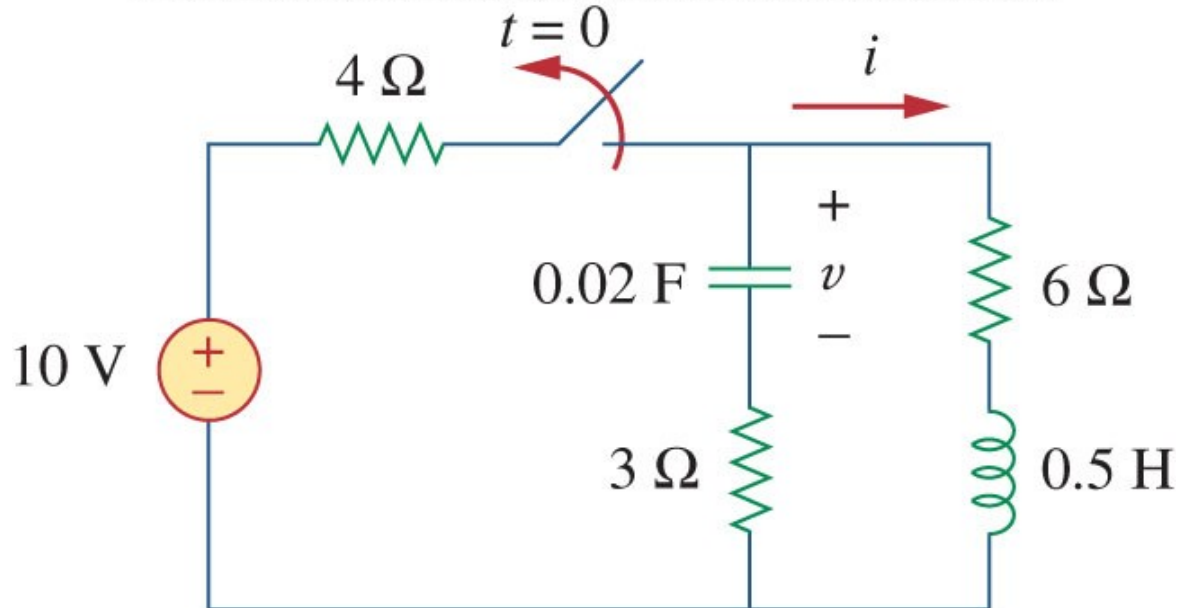





Source-Free Series RLC Circuit - $i(t)$

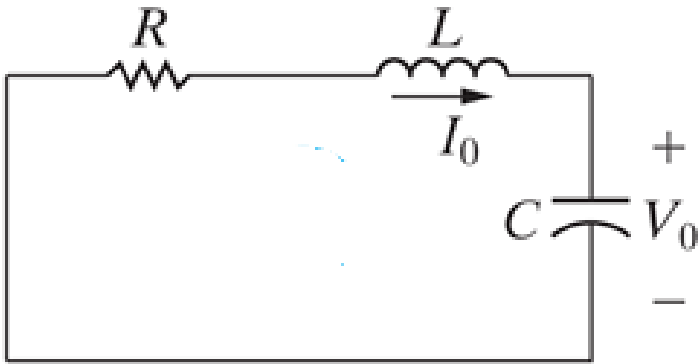



Properties of Series RLC Network - $i(t)$

- Behavior captured by damping
 - Gradual **loss** of the initial stored energy
 - α determines the rate of damping

$$\alpha = \frac{R}{2L} \quad \omega_0 = \frac{1}{\sqrt{LC}}$$

- $\alpha > \omega_0$, overdamped

$$i(t) = A_1 e^{s_1 t} + A_2 e^{s_2 t}$$

- $\alpha = \omega_0$, critically damped

$$i(t) = (A_1 t + A_2) e^{-\alpha t}$$

- $\alpha < \omega_0$, underdamped

$$i(t) = e^{-\alpha t} (B_1 \cos \omega_d t + B_2 \sin \omega_d t)$$

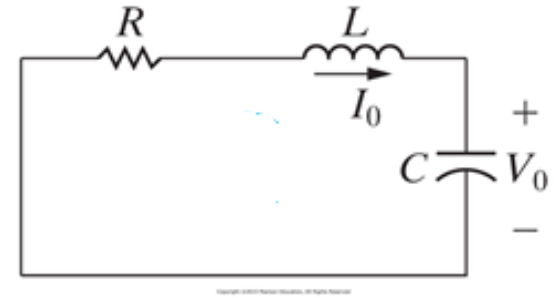





Example

- Find $i(t)$ in the circuit below. Assume the circuit has reached steady state at $t = 0^-$.

Copyright © The McGraw-Hill Companies, Inc. Permission required for reproduction or display

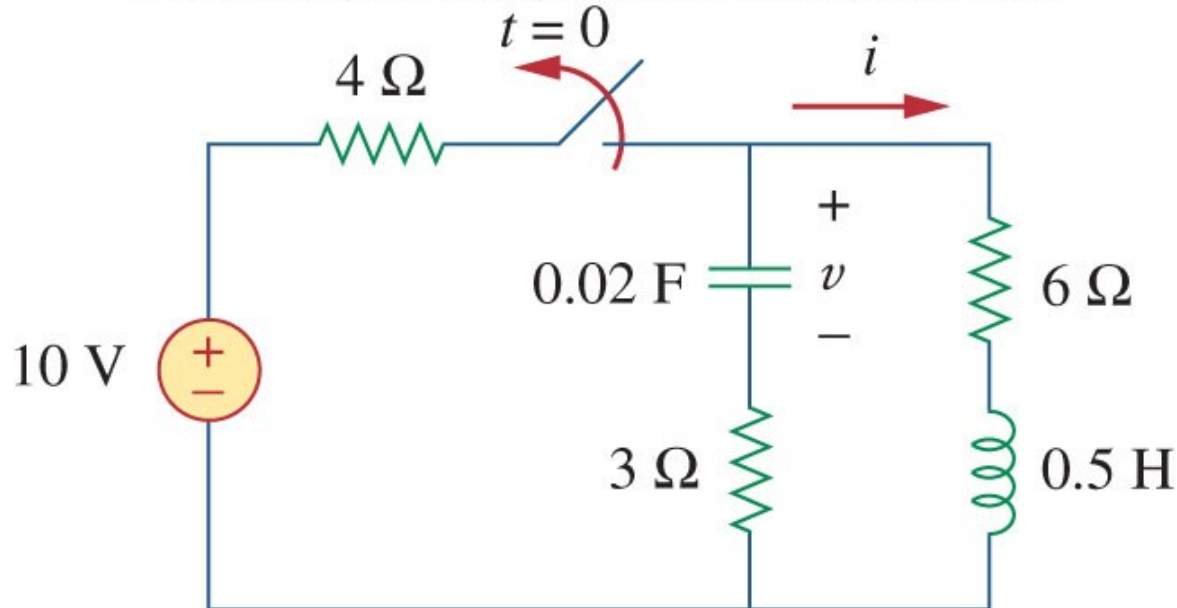



Example

- Find $i(t)$ in the circuit below. Assume the circuit has reached steady state at $t = 0^-$.

Copyright © The McGraw-Hill Companies, Inc. Permission required for reproduction or display

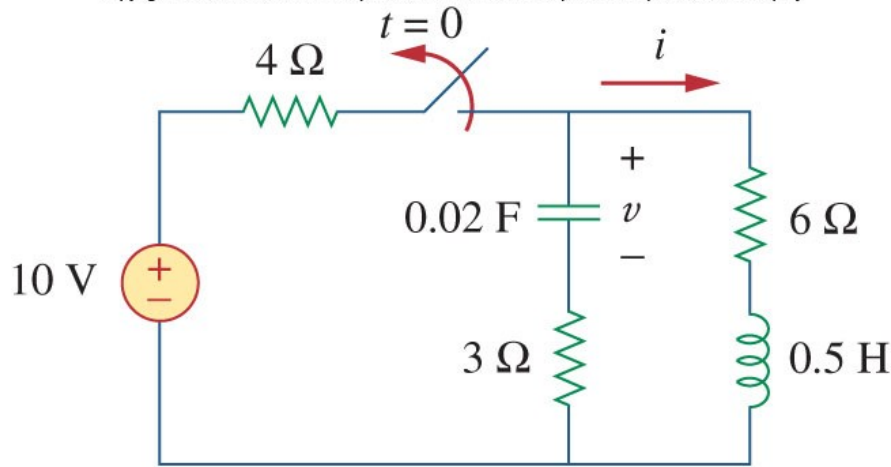

$$\alpha = \frac{R}{2L} = 9 \quad \omega_0 = \frac{1}{\sqrt{LC}} = 10$$

$$s_{1,2} = -\alpha \mp \sqrt{\alpha^2 - \omega_0^2} = -9 \mp j4.359$$

