



Lecture 4

- Operational Amplifiers

The Op. Amp (OA)

- When combined with resistors, capacitors, and inductors, OA can perform various functions:
 - amplification/scaling
 - sign changing
 - addition/subtraction/multiplication/division
 - integration
 - differentiation
 - analog filtering
 - nonlinear functions (exponential, log, sqrt)

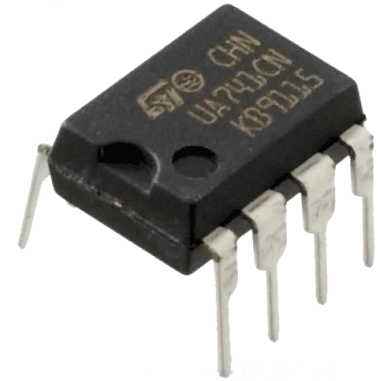

Where do You Use Op AMP?

- Signal generators
- Audio amplifiers
- Hearing aids
- Medical sensor interface
- Baseband receivers
- A/D converters
- Oscillators
- Voltage regulators
- Active filters

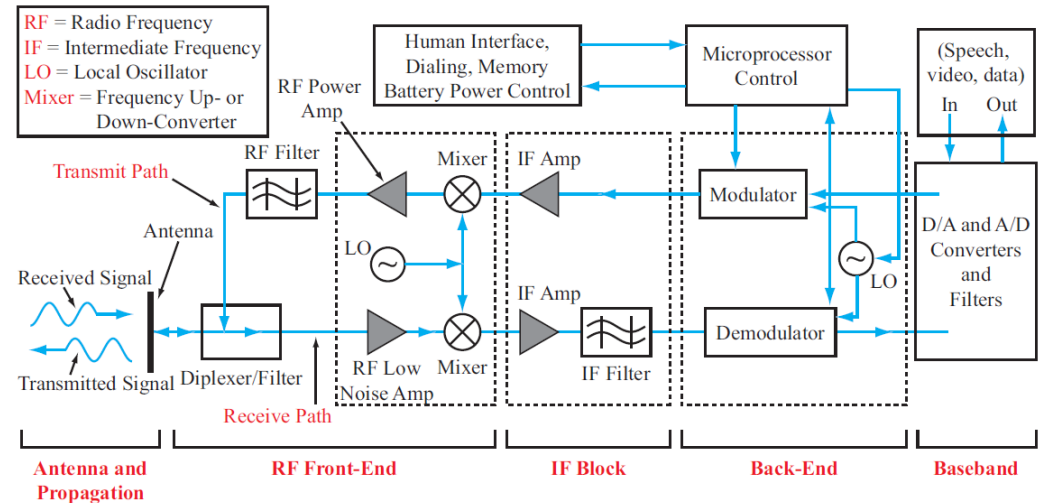
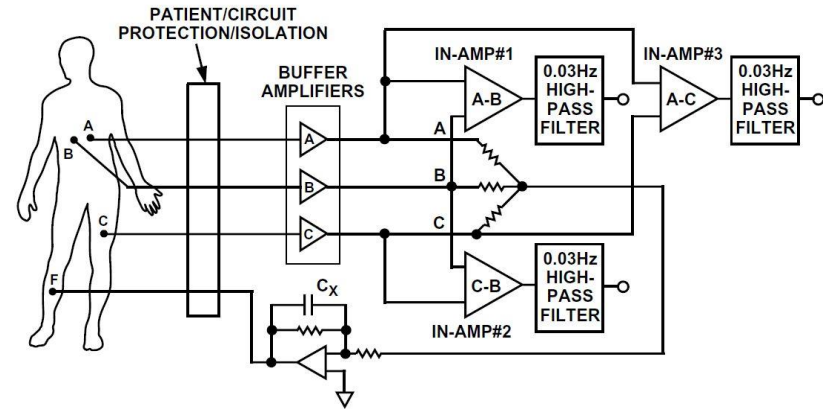



Brief History

- The Operational Amplifier (op amp) was invented in the 40's.
 - Bell Labs filed a patent in 1941.
- Many consider the first practical op amp to be the vacuum tube K2-W invented in 1952 by George Philbrick.
- Bob Widlar at Fairchild invented the $\mu\text{A}702$ op amp in 1963.
- Until $\mu\text{A}741$, released in 1968, op amps became relatively inexpensive and started on the road to ubiquity.

https://en.wikipedia.org/wiki/Operational_amplifier

Op Amp Terminals

Copyright © The McGraw-Hill Companies, Inc. Permission required for reproduction or display

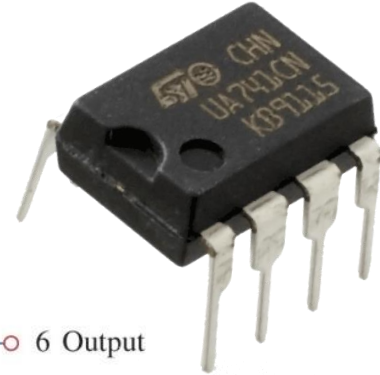
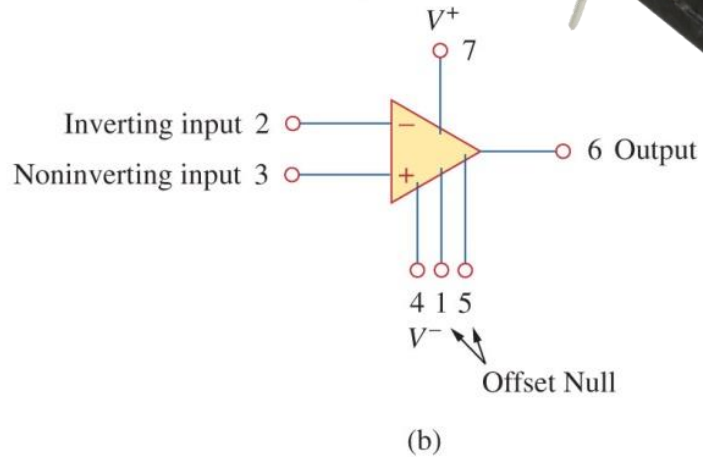
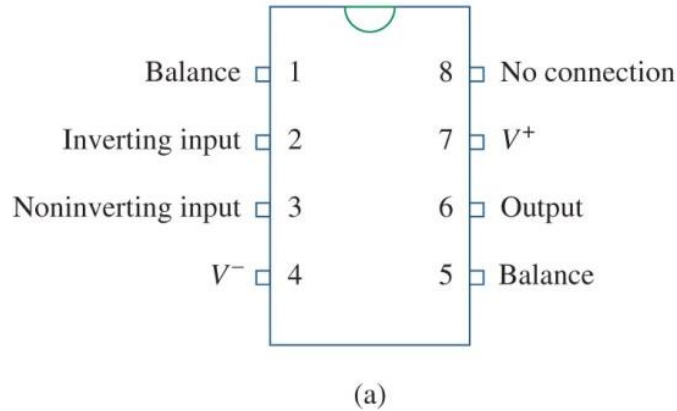

- **Five** important terminals

- The inverting input
- The noninverting input
- The output
- The positive (+) power supply
- The negative (-) power supply

- The rest three terminals

- 2 Offset Null (Balance)
 - May used in auxiliary circuit to compensate for performance degradation due to aging etc.
- 1 No Connection (NC)
 - Unused, not connected to the amplifier circuit.



Input and Output

- The voltage output of an op-amp is **proportional** to the **voltage difference** between the noninverting and inverting inputs

$$v_o = Av_d = A(v_2 - v_1)$$

Here, A is called the open loop gain.

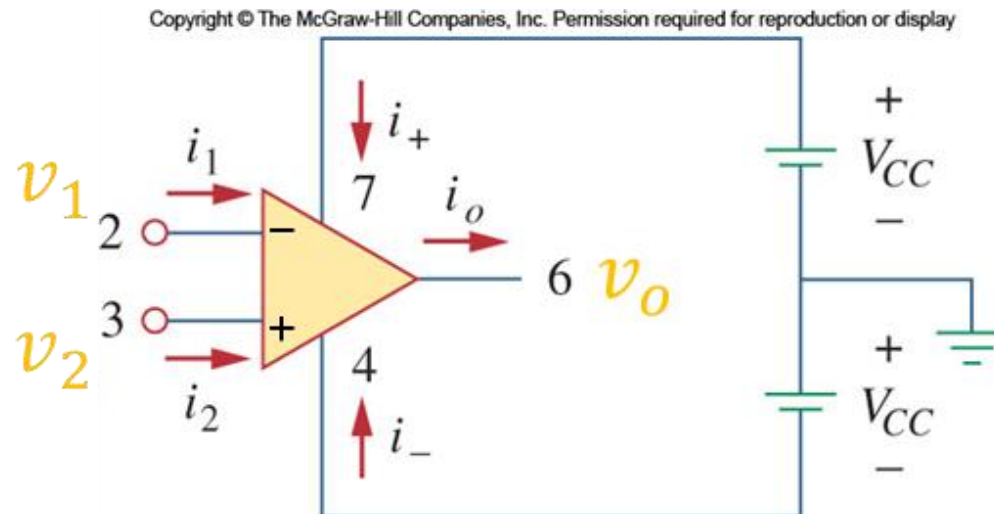



Output Voltage Saturation

- Is the output voltage unlimited?

Copyright © The McGraw-Hill Companies, Inc. Permission required for reproduction or display

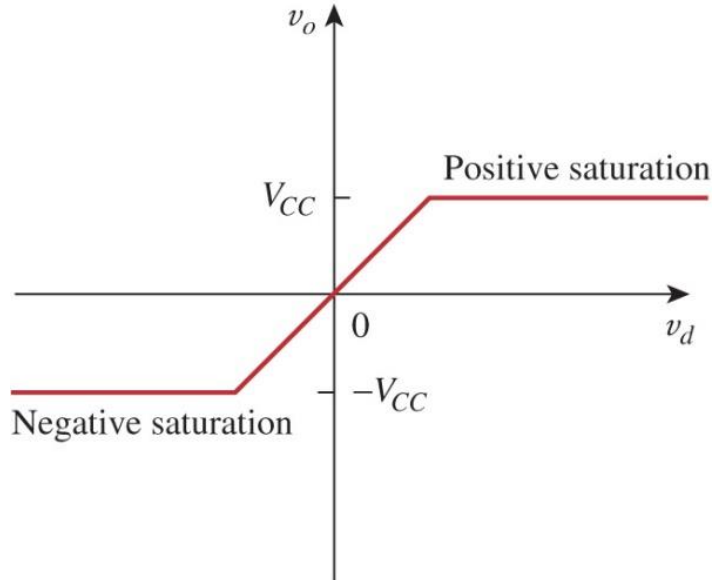

Copyright © The McGraw-Hill Companies, Inc. Permission required for reproduction or display

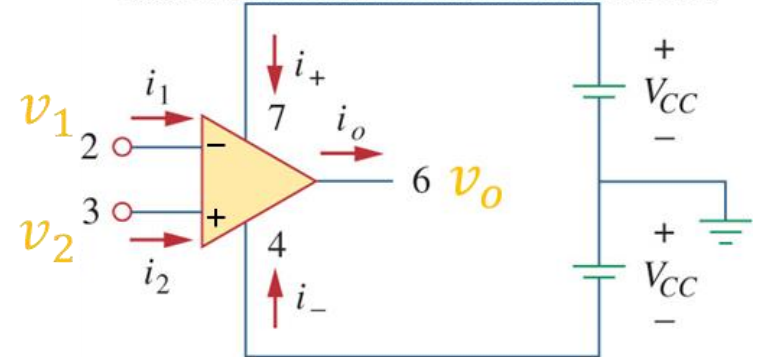

$$v_o = Av_d = A(v_2 - v_1)$$

$$v_o = \begin{cases} -V_{cc} & Av_d < -V_{cc} \\ Av_d & -V_{cc} \leq Av_d \leq +V_{cc} \\ +V_{cc} & Av_d > +V_{cc} \end{cases}$$

Output Voltage

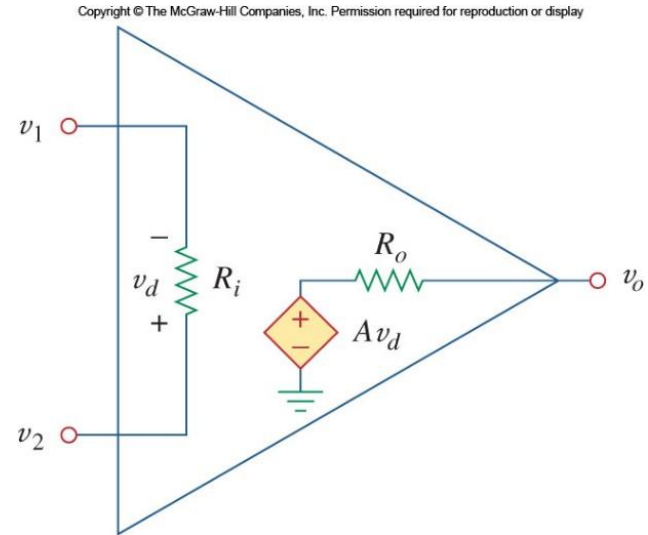
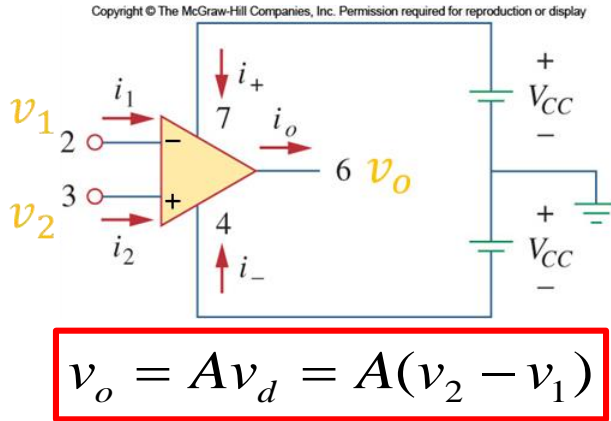

- Ideally A is infinite. In real devices, it is still high: 10^5 to 10^8 .

Copyright © The McGraw-Hill Companies, Inc. Permission required for reproduction or display

TABLE 5.1

Typical ranges for op amp parameters.

Parameter	Typical range	Ideal values
Open-loop gain, A	10^5 to 10^8	∞
Input resistance, R_i	10^5 to $10^{13} \Omega$	$\infty \Omega$
Output resistance, R_o	10 to 100 Ω	0Ω
Supply voltage, V_{CC}	5 to 24 V	

Ideal Op Amp

- Attributes of ideal op-amp:
 - infinite open-loop gain, $A \simeq \infty$
 - Implies that $v_2 = v_1$.
 - infinite resistance of the two inputs, $R_i \simeq \infty$
 - Implies that $i_1 = i_2 = 0$.
 - zero output impedance, $R_o \simeq 0$
 - Implies that output voltage is **load independent**.

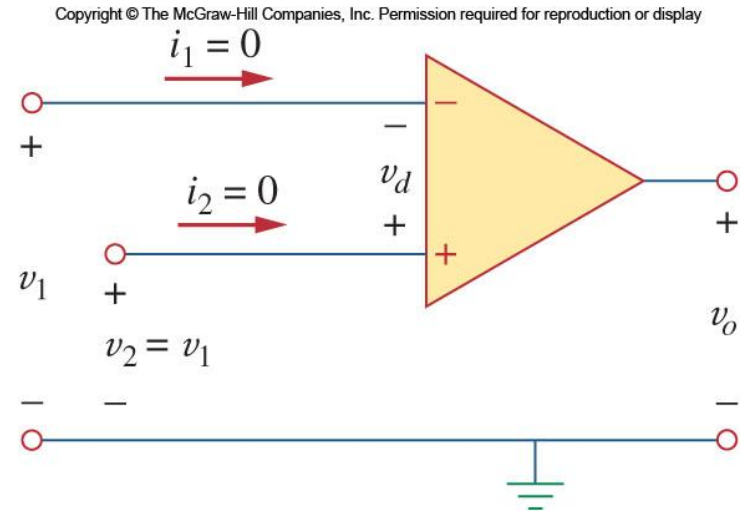
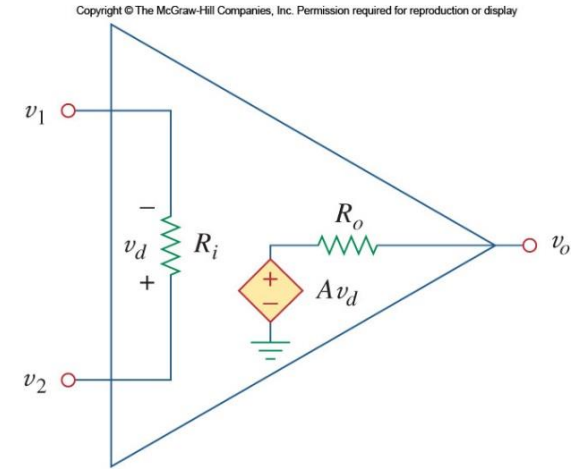



Ideal Op-Amp Analysis – Golden Rules

Assumption 1: The **potential** difference between the op-amp input terminals, $v_{(+)} - v_{(-)}$, equals **zero**.

Assumption 2: The **currents** flowing into the op-amp's two input terminals both equal **zero**.

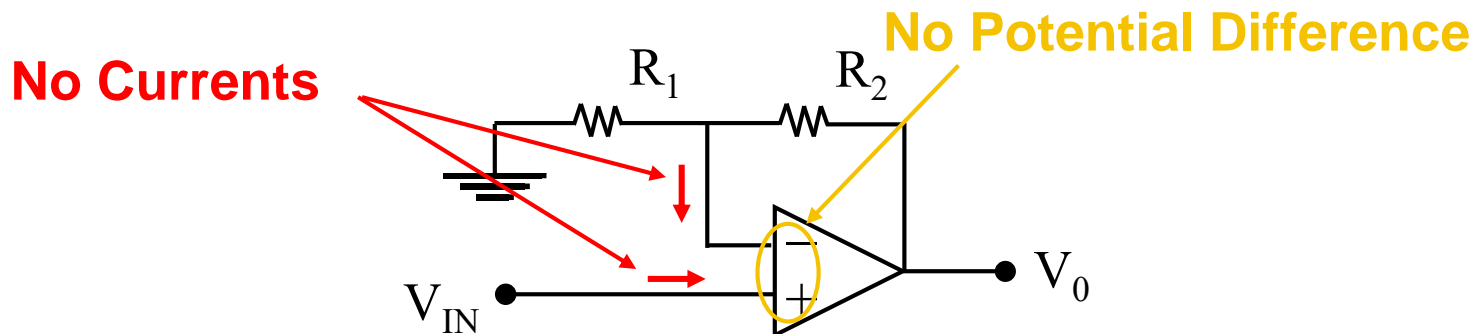



Inverting Amplifier

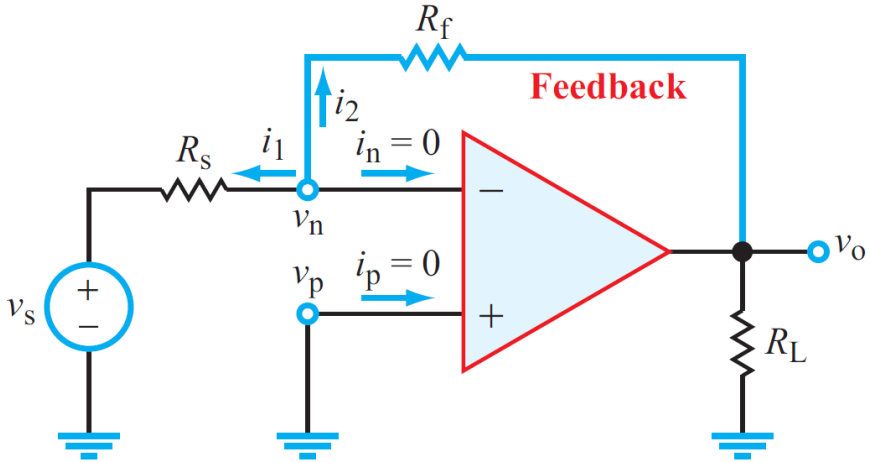



Example

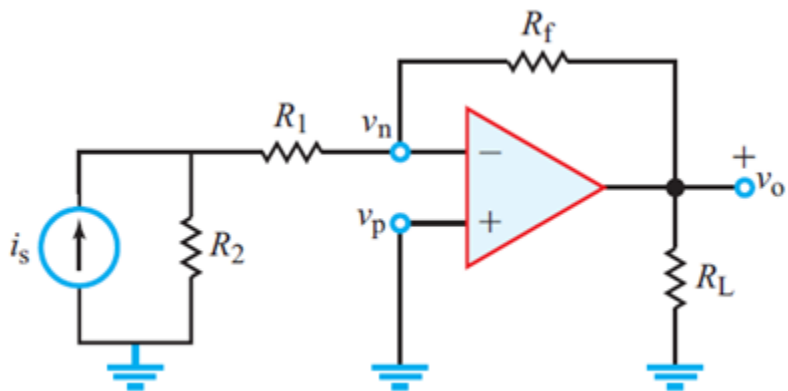



Practice

- Determine v_o in the circuit shown below

Copyright © The McGraw-Hill Companies, Inc. Permission required for reproduction or display

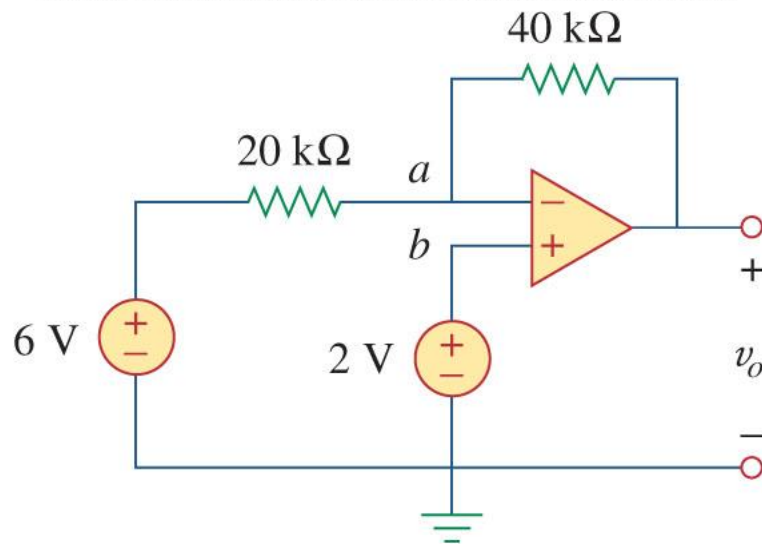



Non-Inverting Amplifier

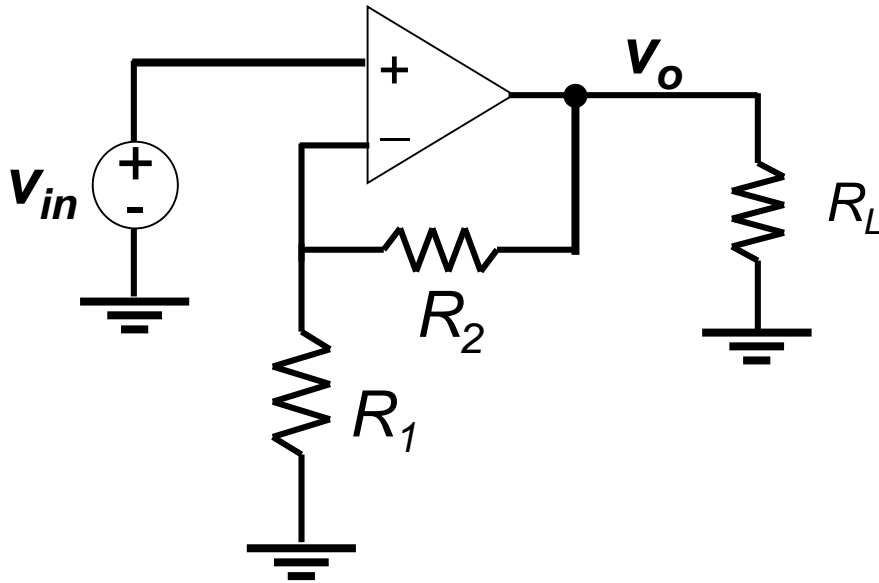



Application: Voltage Follower

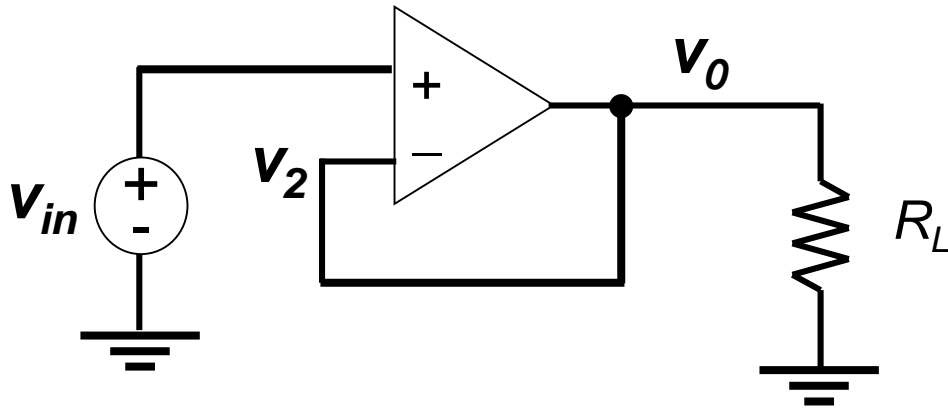



Application of Voltage Follower

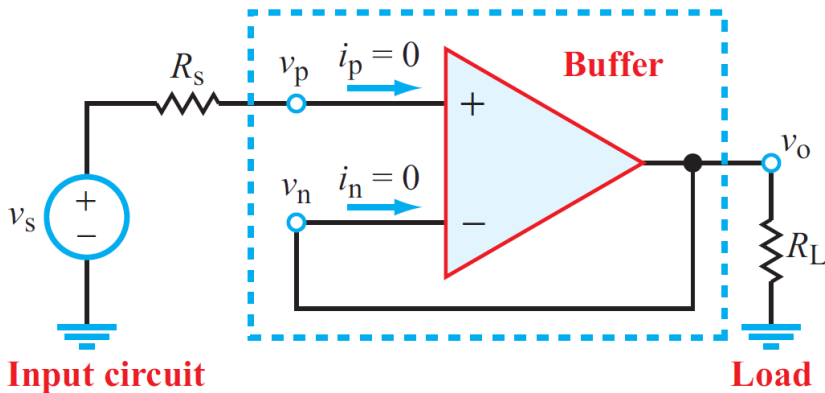
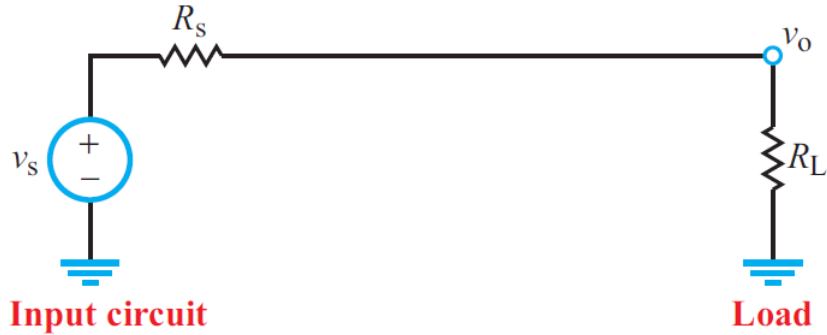

“Buffer” sections of Circuit



Negative Feedback

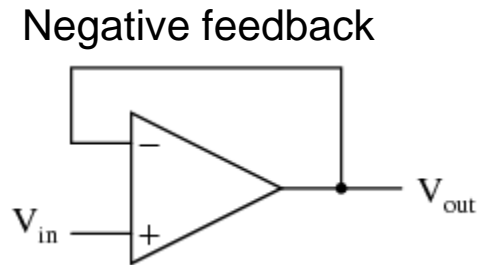

- A self-stabilizing system (also true for any dynamic system in general), giving the op-amp the capacity to work in its linear (active) mode.



How Negative Feedback Works?

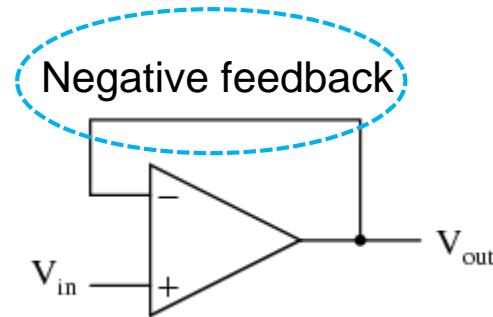

$V_{in} \uparrow \Rightarrow$ voltage difference $\uparrow \Rightarrow V_{out} \uparrow$
 \Rightarrow voltage difference $\downarrow \Rightarrow V_{out} \downarrow$
 $\Rightarrow \dots$
 $\Rightarrow V_{out} \rightarrow V_{in}$ but small difference exists

Summing Amplifier

- Aside from amplification, the op-amp can be made to do addition very readily.

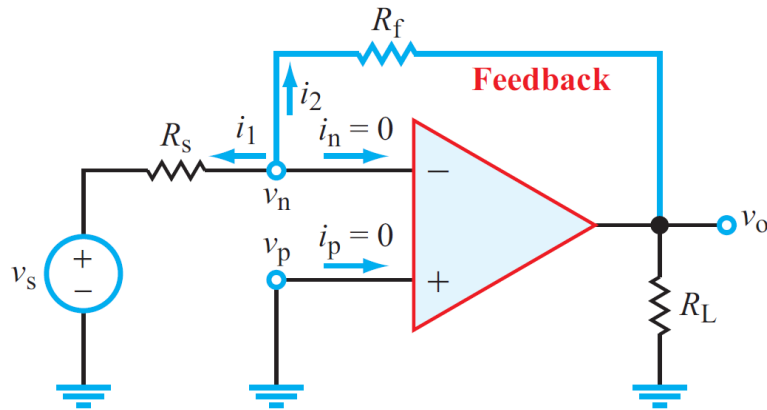

Copyright © The McGraw-Hill Companies, Inc. Permission required for reproduction or display

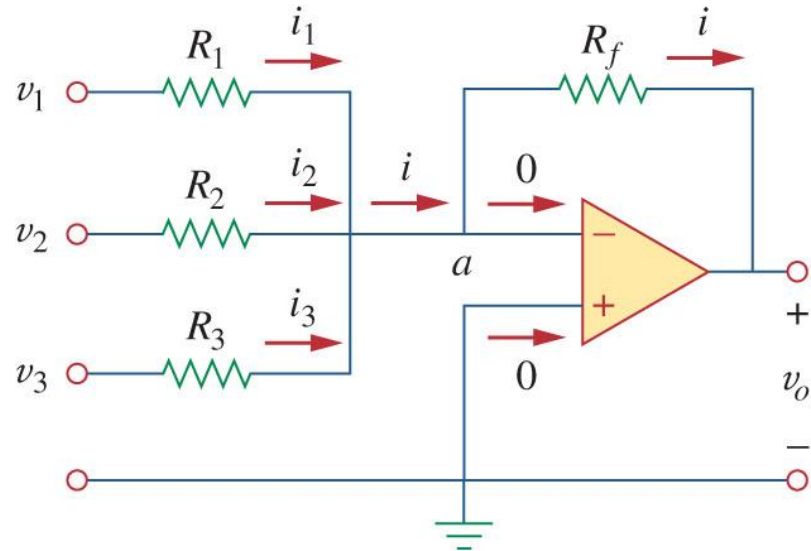



Practice

- Find v_o and i_o in the circuit shown below

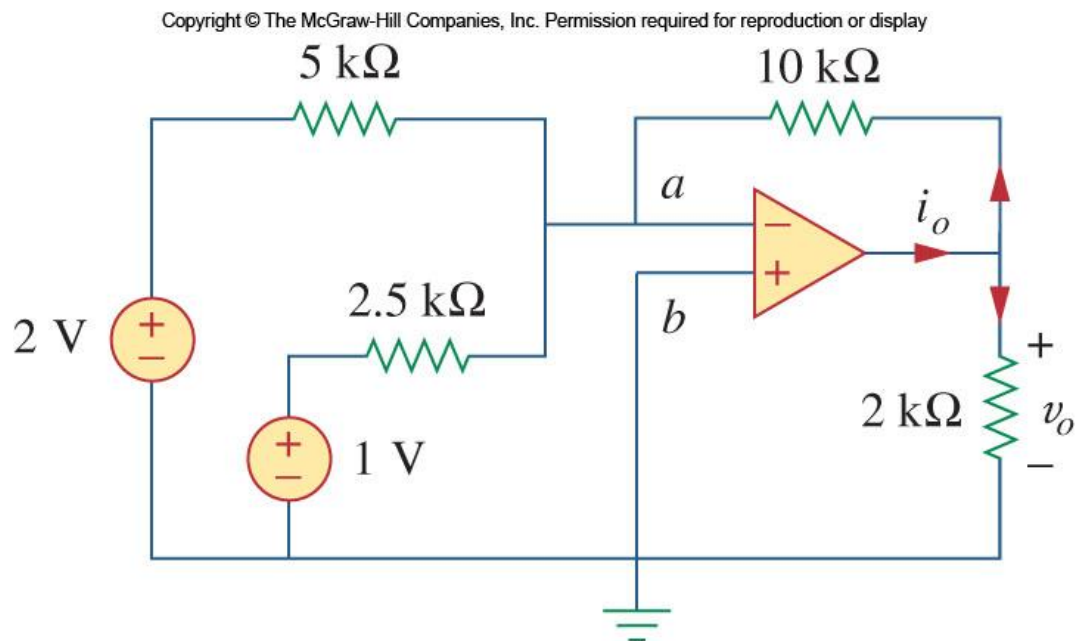



Difference Amplifier

Copyright © The McGraw-Hill Companies, Inc. Permission required for reproduction or display

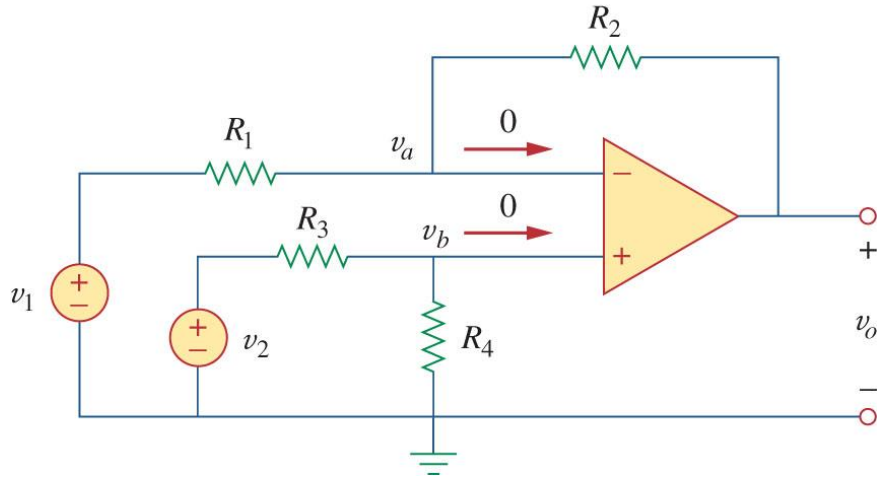

Common Mode Rejection

Copyright © The McGraw-Hill Companies, Inc. Permission required for reproduction or display

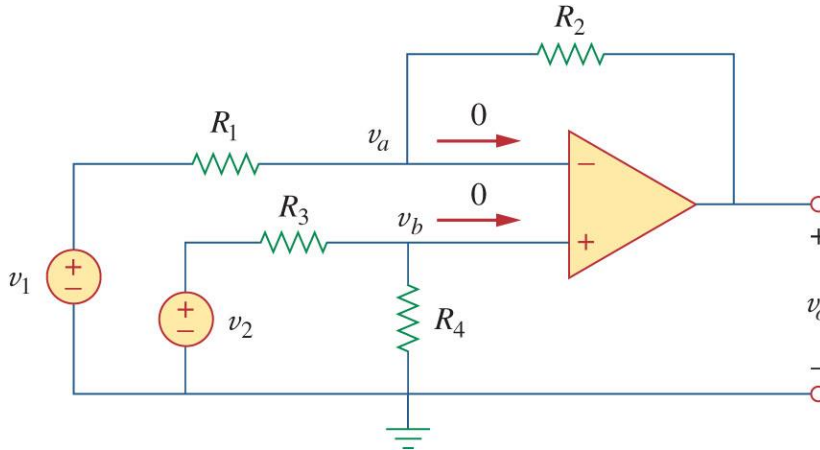

$$v_o = \frac{R_2 (1 + R_1/R_2)}{R_1 (1 + R_3/R_4)} v_2 - \frac{R_2}{R_1} v_1$$

- It is important that a difference amplifier rejects any signal that is common to the two inputs.
 - Which implies that when $v_1 = v_2$, $v_o = 0$.



Cascaded Op Amps

- This head to tail configuration is called “cascading”.
 - Each amplifier is then called a “stage”.

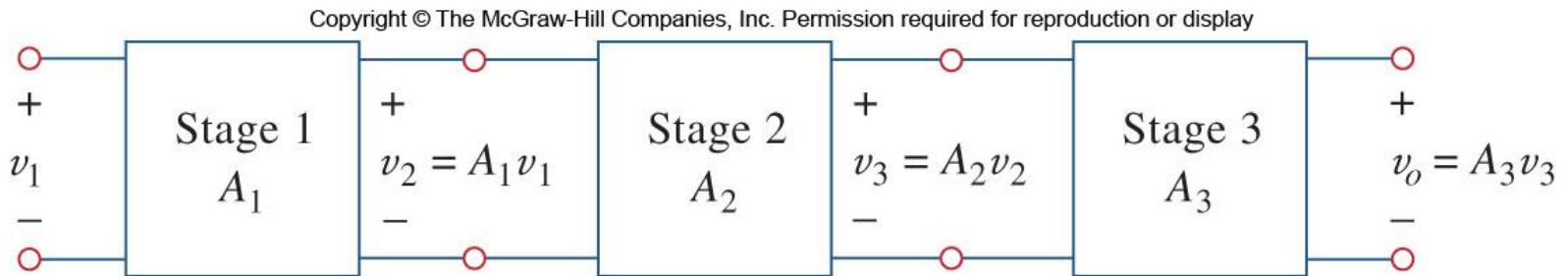

- The gain of a series of amplifiers is the product of the individual gains:

$$A = A_1 \cdot A_2 \cdot A_3$$



Example

Design a circuit that performs the operation

$$v_o = 4v_1 + 7v_2.$$



Summary

Op amp circuit

Name/output-input relationship

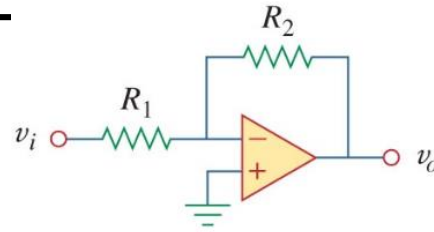

Inverting amplifier

$$v_o = -\frac{R_2}{R_1}v_i$$

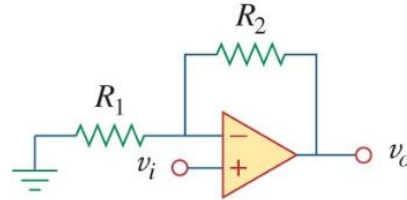

Noninverting amplifier

$$v_o = \left(1 + \frac{R_2}{R_1}\right)v_i$$

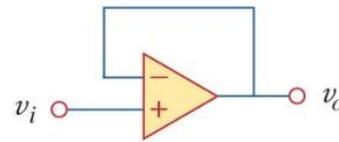

Voltage follower

$$v_o = v_i$$

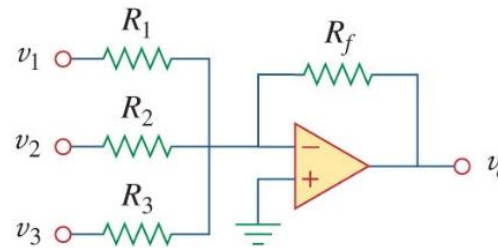

Summer

$$v_o = -\left(\frac{R_f}{R_1}v_1 + \frac{R_f}{R_2}v_2 + \frac{R_f}{R_3}v_3\right)$$

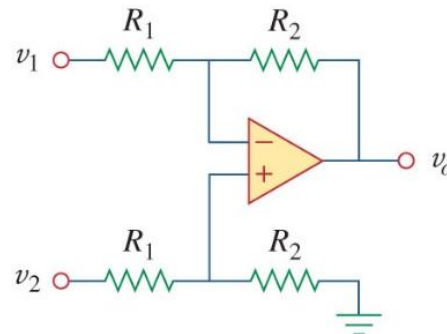

Difference amplifier

$$v_o = \frac{R_2}{R_1}(v_2 - v_1)$$