



Lecture 3

Circuit Theorems



Outline

- Linearity property
- Superposition
- Thevenin's theorem
- Source transformation
- Norton's theorem
- Power transfer



Linear Circuit

- A linear circuit consists of only linear elements (resistors, capacitors and inductors), linear dependent sources, and independent sources.
- In a circuit,
 - Excitation: Sources
 - Response: Voltage or current in the branches

Copyright © The McGraw-Hill Companies, Inc. Permission required for reproduction or display

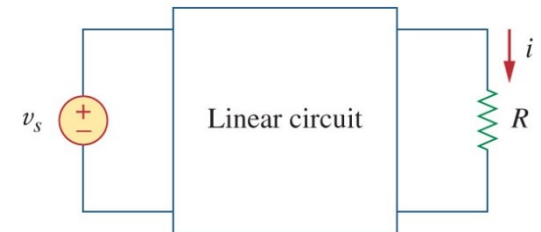



Linearity Property



- Linearity is a combination of
 - homogeneity (scaling) property

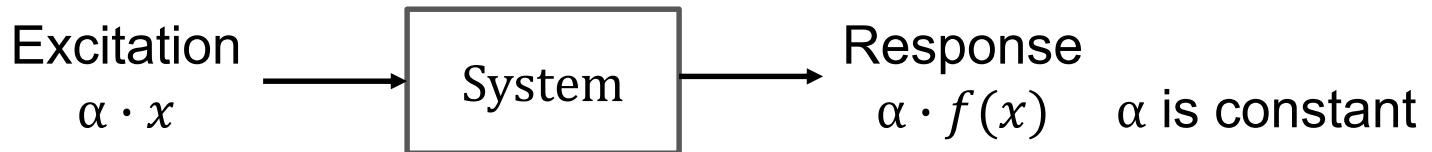

- additivity property





Example of homogeneity (scaling) property

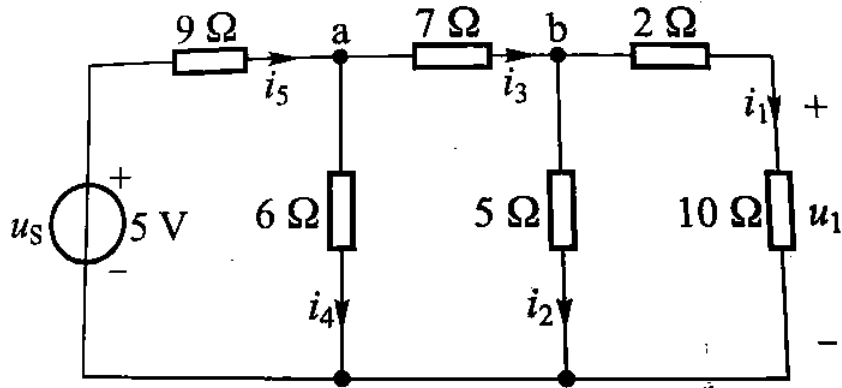



Superposition

- The superposition principle states that the voltage across (or current through) an element in *a linear circuit* is the algebraic sum of the voltages across (or currents through) that element due to each independent source acting alone.

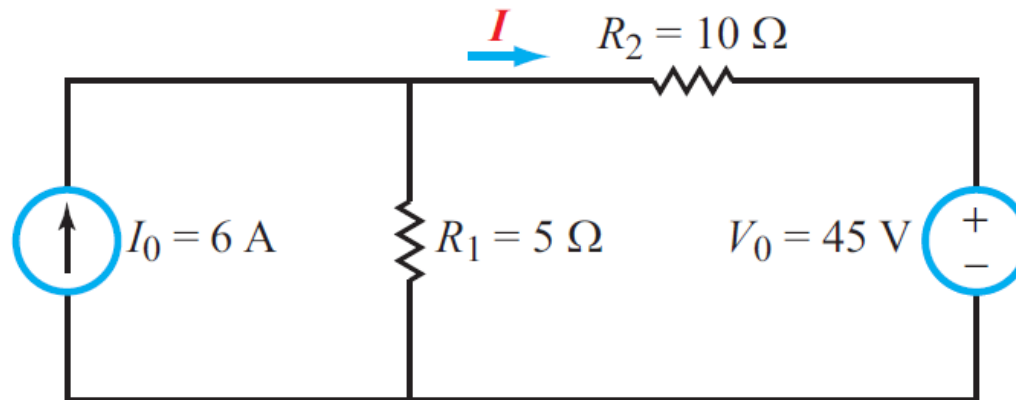



Applying Superposition

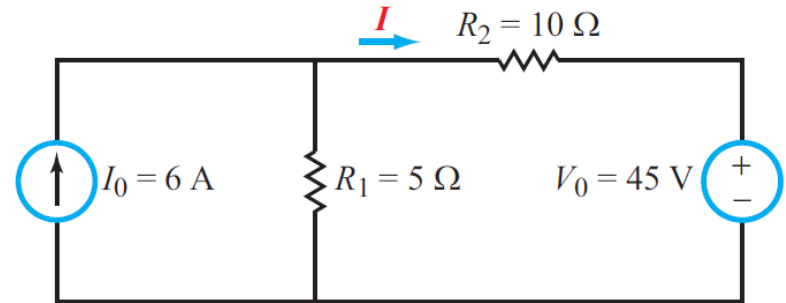

• The steps are:

1. Turn off all other **independent** sources except for the source of interest. Find the output (voltage or current) due to that **active** source.
 - “Turn off” means to replace **independent** voltage source by short circuit (0 V), **independent** current source by open circuit (0 A).
2. Repeat step 1 for **each independent** source.
3. Find the total contribution by adding algebraically **all** the contributions due to the **independent** sources.

Note that

- 1) Using superposition means applying one independent source at a time.
- 2) **Dependent sources are left alone.**



Open Circuit and Short Circuit

- Turn off an independent voltage source means
 - $v=0$
 - Replace by wire
 - Short circuit
- Turn off an independent current source means
 - $i=0$
 - Cut off the branch
 - Open circuit

Copyright © The McGraw-Hill Companies, Inc. Permission required for reproduction or display

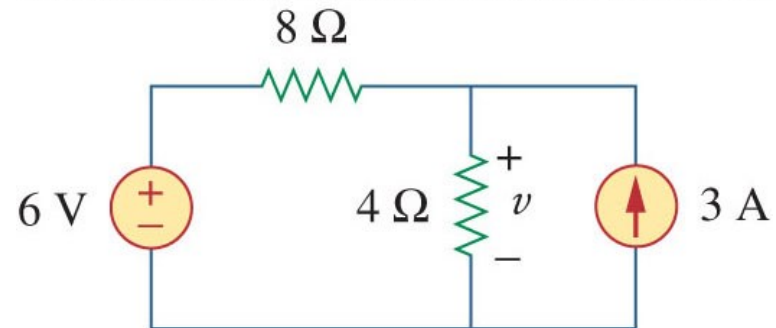



Example: Superposition

Calculate I

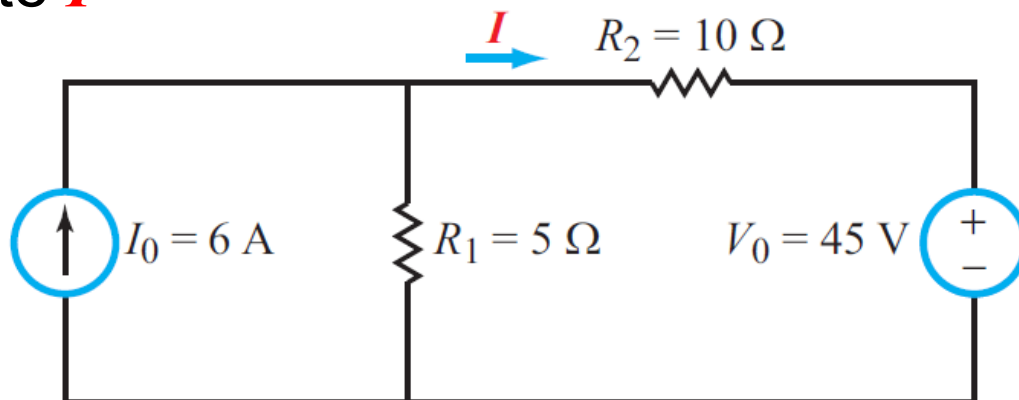



Example: Superposition

Calculate I

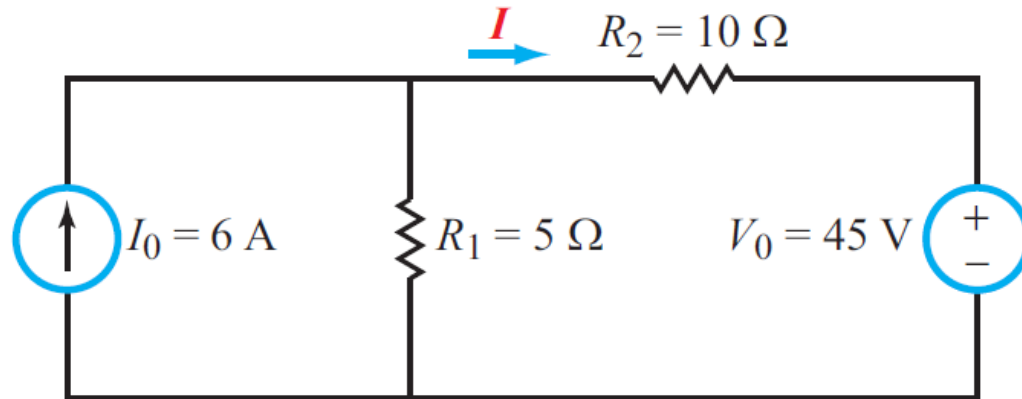

Contribution from I_0 alone

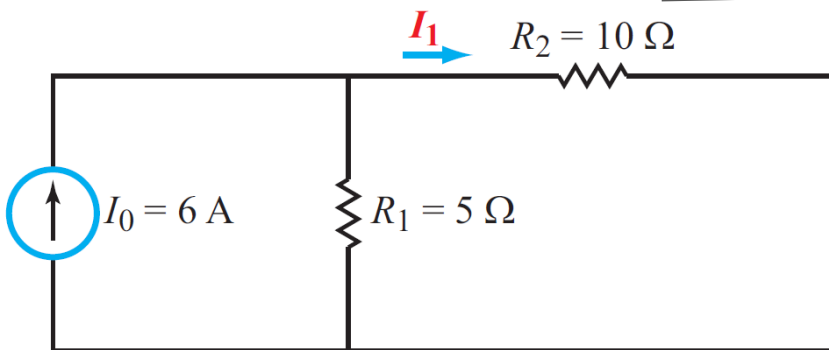

$$I_1 = 2 \text{ A}$$

Contribution from V_0 alone

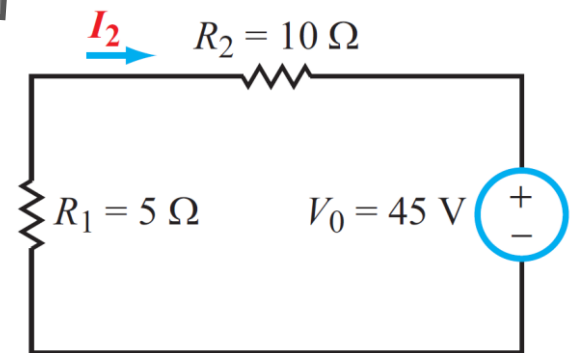

$$I_2 = -3 \text{ A}$$

$$I = I_1 + I_2 = 2 - 3 = -1 \text{ A}$$



Why Superposition?

- It is useful to evaluate the sensitivity of a response to specific sources in the circuit.
- Because it entails solving a circuit multiple times, this source-superposition method may not be attractive.

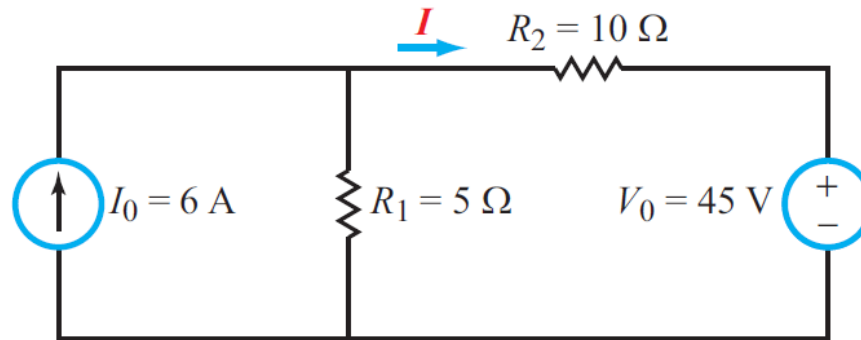

$$I = aI_0 + bV_0$$



How about Power absorbed by R_2

- Power due to I_0 , $P_1 = ?$
- Power due to V_0 , $P_2 = ?$
- Power due to both V_0 and I_0 , $P = ?$

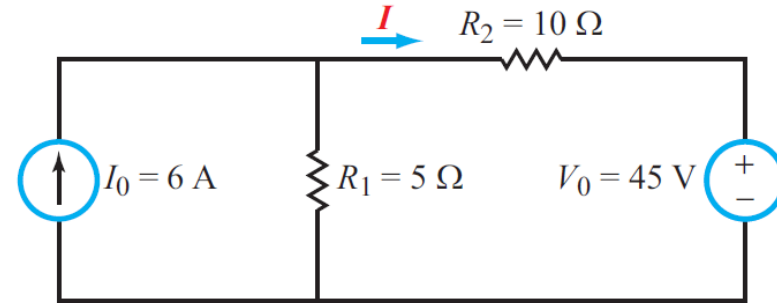



Practice 1

- Find i_o in the circuit shown below.

Copyright © The McGraw-Hill Companies, Inc. Permission required for reproduction or display

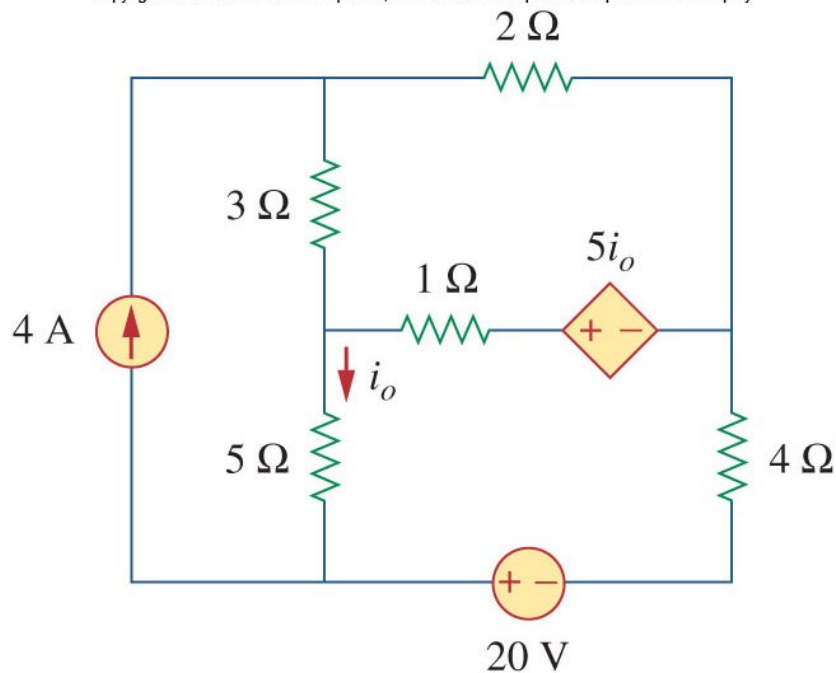

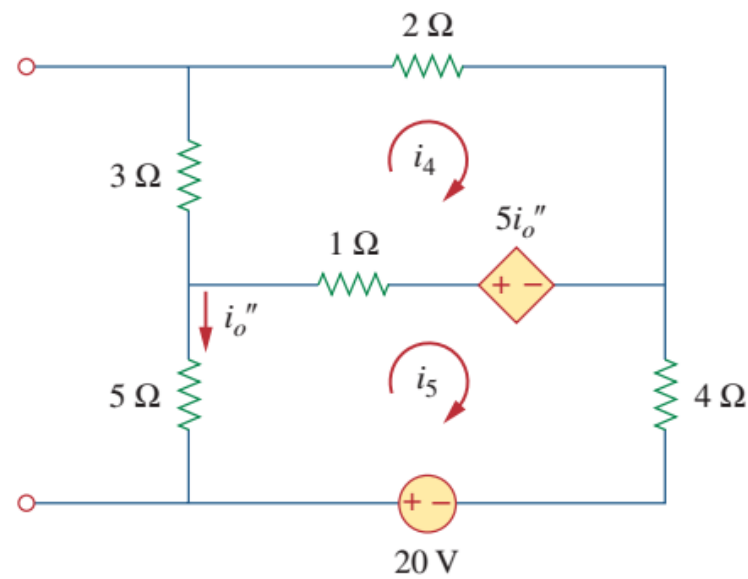
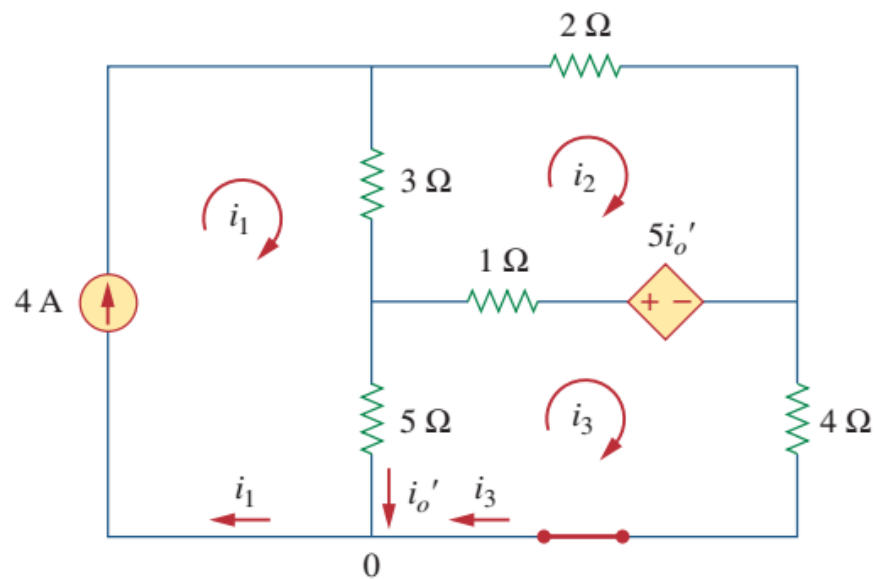



Outline

- Linearity property
- Superposition
- Thevenin's theorem
- Source transformation
- Norton's theorem
- Power transfer



Example

- Q1: If $R_2 = 1\Omega$, $I = ?$
- Q2: What if $R_2 = 5\Omega$, $I = ?$
- ??

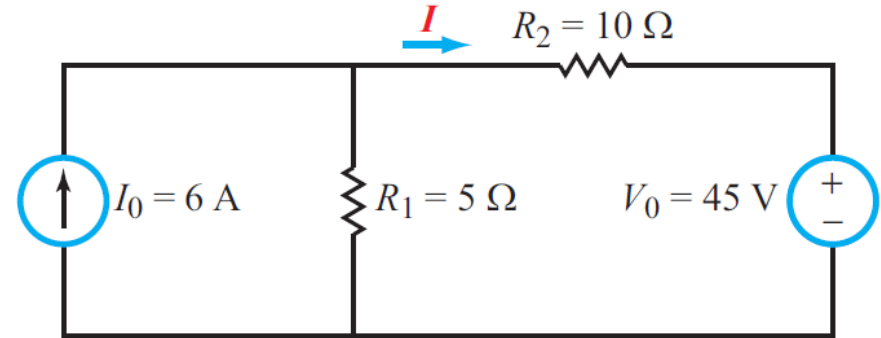



Thevenin's Theorem – Motivation

- In many circuits, it is quite common that only one element (called *the load*) is variable while others are fixed.
 - An example is the household outlet: different appliances may be plugged into the outlet, each presenting a different resistance.
 - Ordinarily one has to **re-analyze** the circuit upon changing load.
 - This complexity can be simplified by **circuit theorem** (e.g. Thevenin's theorem), which provides a technique to **replace the fixed part of the circuit with an equivalent circuit**.

Thevenin's Theorem (1880s, Leon Thevenin, French)

- Thevenin's theorem states that a two terminal circuit (including resistors, linear dependent sources, and independent sources.) may be replaced with a voltage source in series with a resistor:

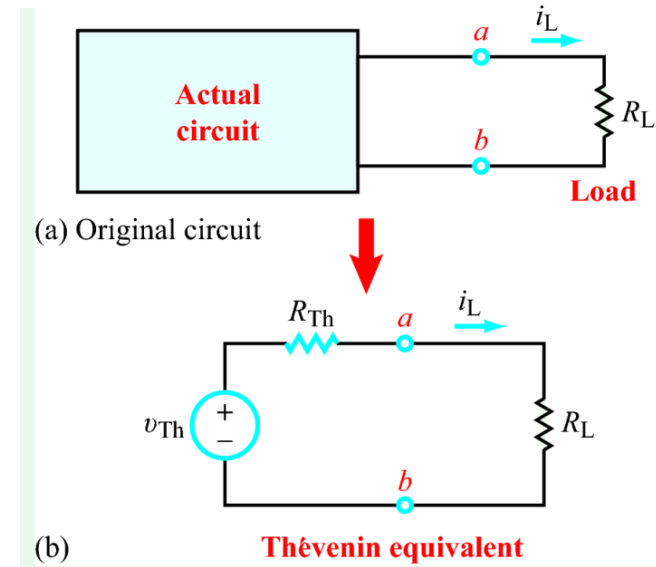

≡

Thévenin equivalent circuit

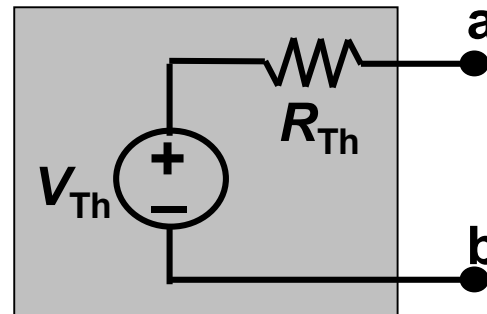

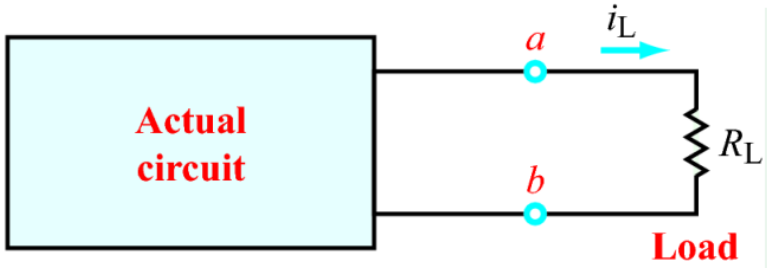



Example

- Use Thévenin Equivalent Circuits
- Q1: If $R_2 = 1\Omega$, $I = ?$
- Q2: What if $R_2 = 5\Omega$, $I = ?$

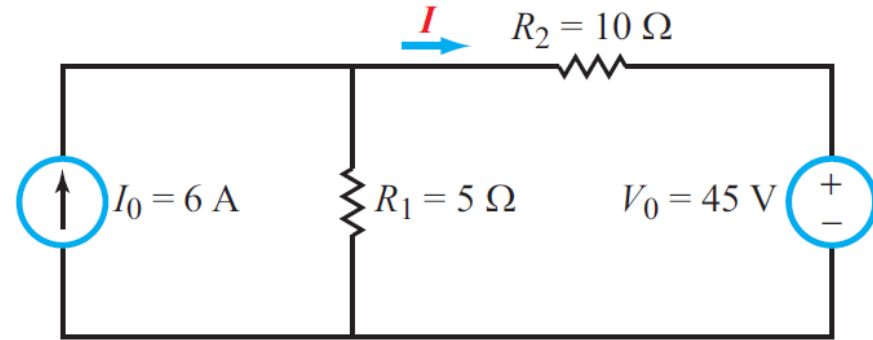

How Do We Find Thévenin Equivalent Circuits?

Method 1: Equivalent Resistance

1. Analyze circuit to find v_{oc}
2. **Deactivate** all **independent** sources by replacing voltage sources with short circuits and current sources with open circuits.
3. Simplify circuit to find equivalent resistance.

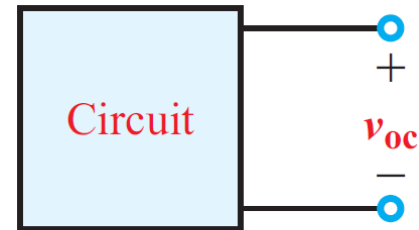

(a) $v_{Th} = v_{oc}$

Equivalent-Resistance Method

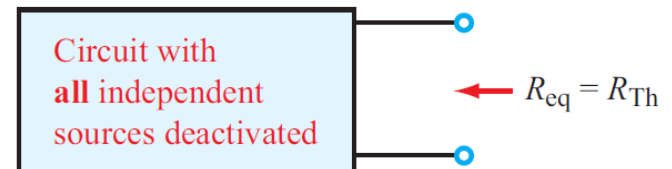

Note: This method **does not** apply to circuits that contain **dependent** sources.



Example

Thévenin Equivalent Circuit

(Circuit has no dependent sources)

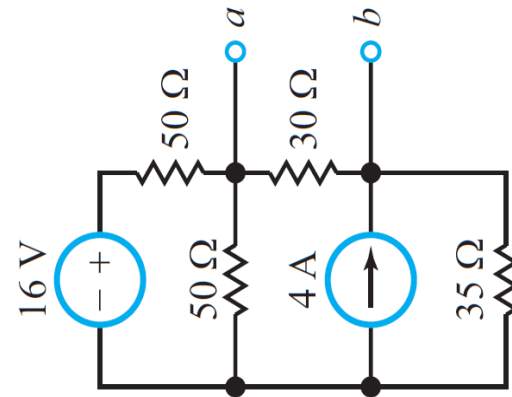
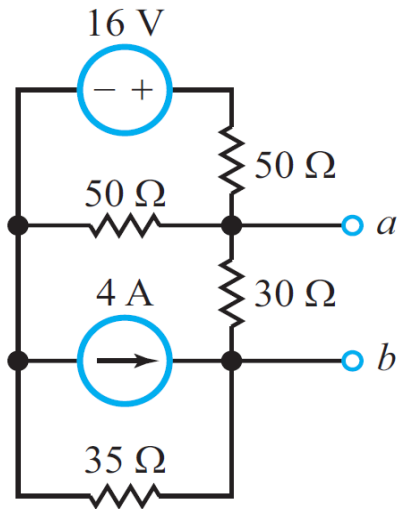

How Do We Find Thévenin Equivalent Circuits ?

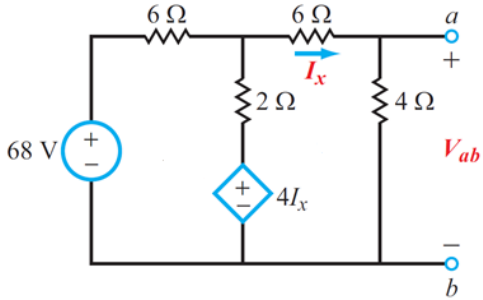

Method 2: Open/short circuit

1. Analyze circuit to find v_{oc}
2. Analyze circuit to find i_{sc}

$$v_{Th} = v_{oc}$$

$$R_{Th} = \frac{v_{oc}}{i_{sc}}$$

Note: This method is applicable to **any linear circuit**, whether or not it contains dependent sources.

Open-Circuit / Short-Circuit Method

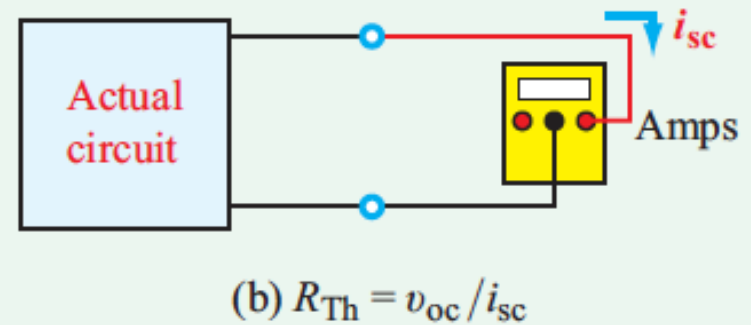
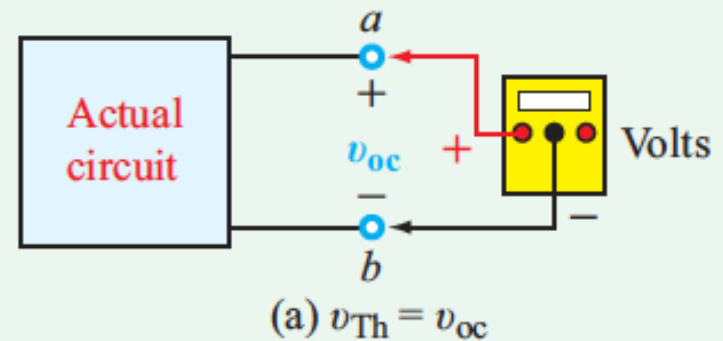



Example

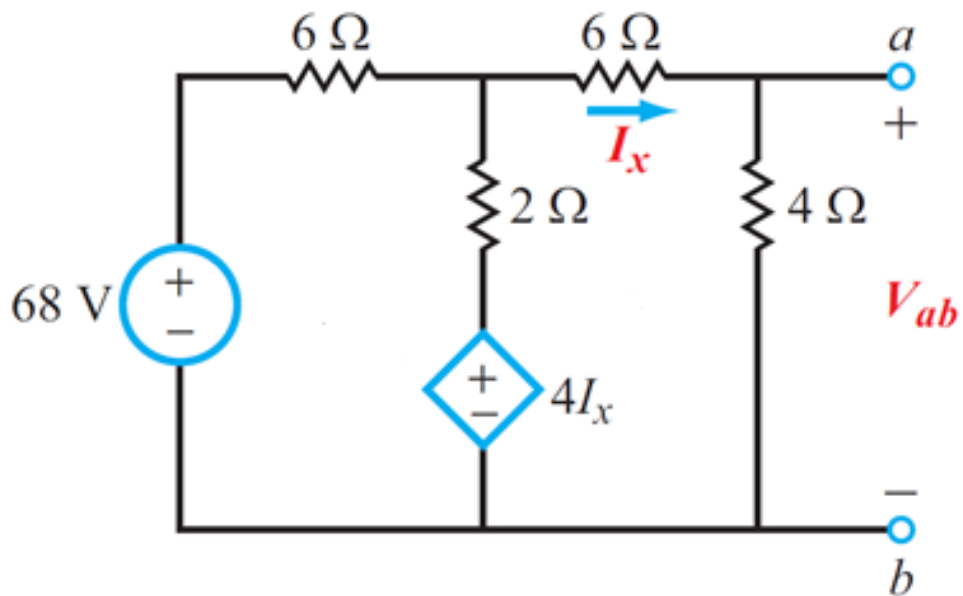



Practice

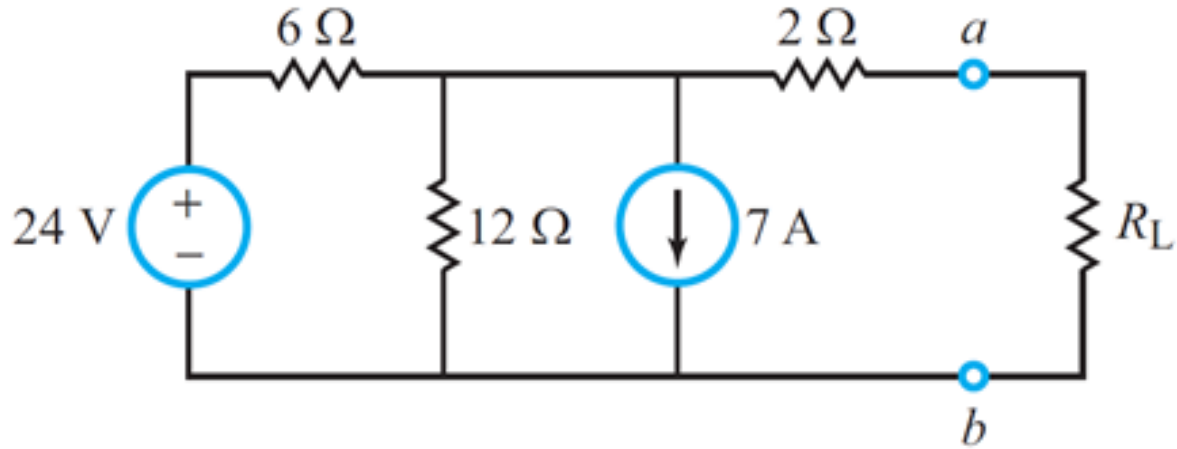



How Do We Find Thévenin Equivalent Circuits?

Method 3:

Step 1. **Again** $v_{Th} = v_{oc}$

Step 2. **External-Source Method**

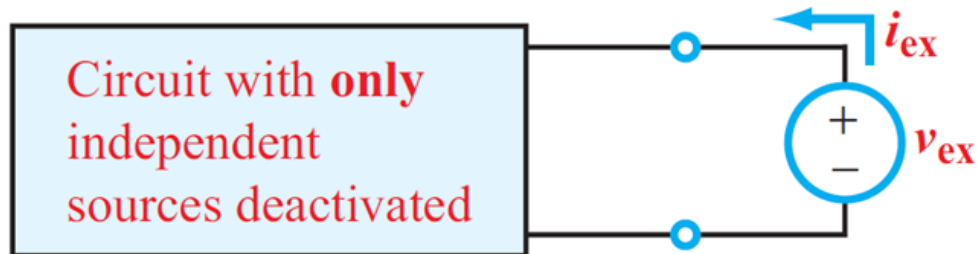

If a circuit contains both dependent and independent sources, R_{Th} can be determined by (a) deactivating independent sources (only), (b) adding an external source v_{ex} , and then (c) solving the circuit to determine i_{ex} . The solution is $R_{Th} = v_{ex}/i_{ex}$.



Example

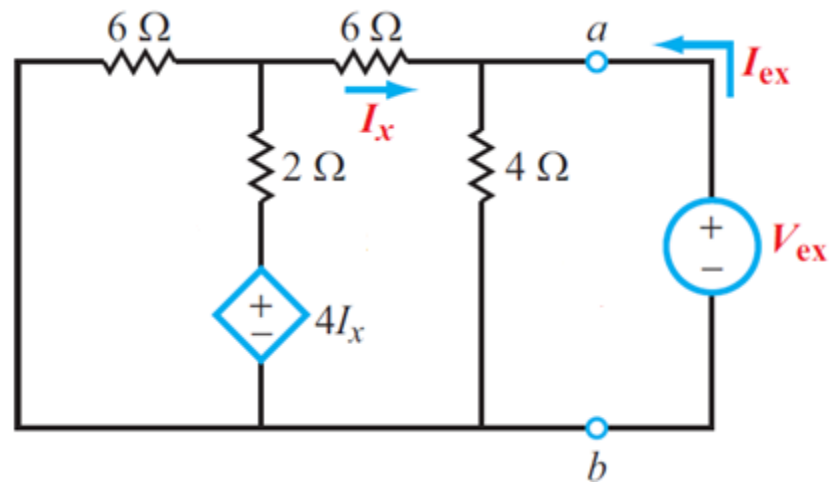
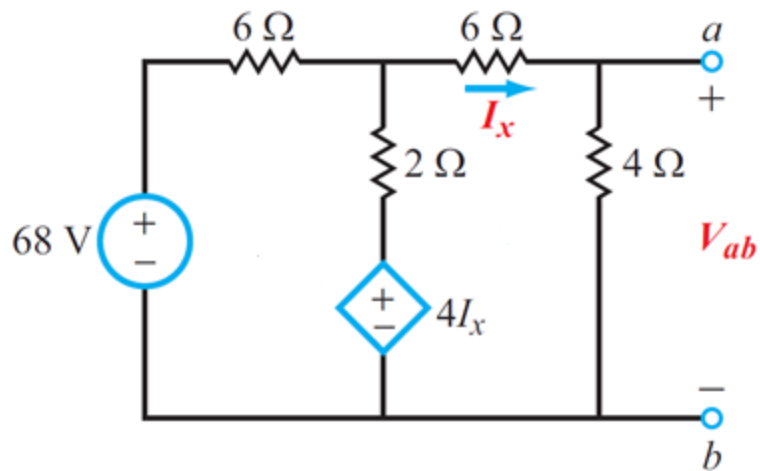



Example

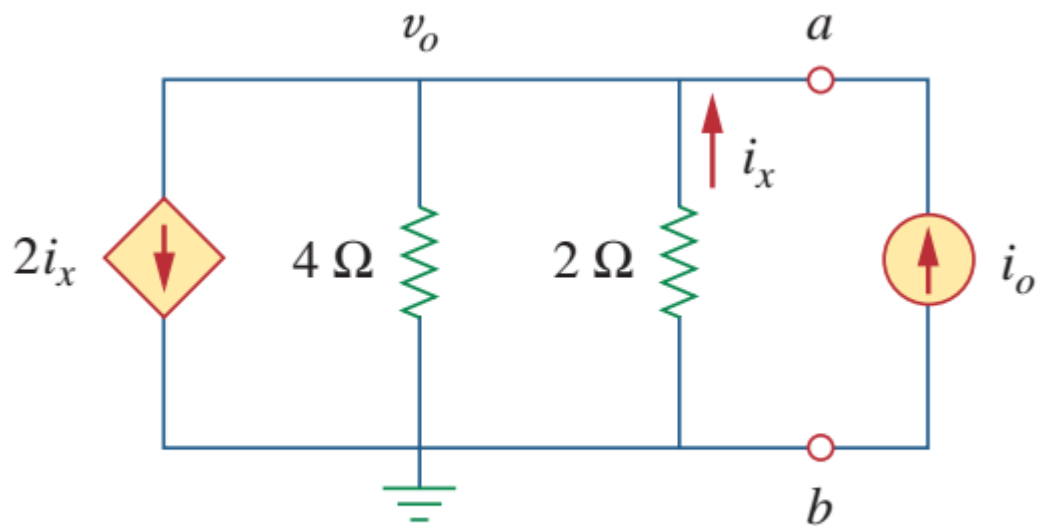
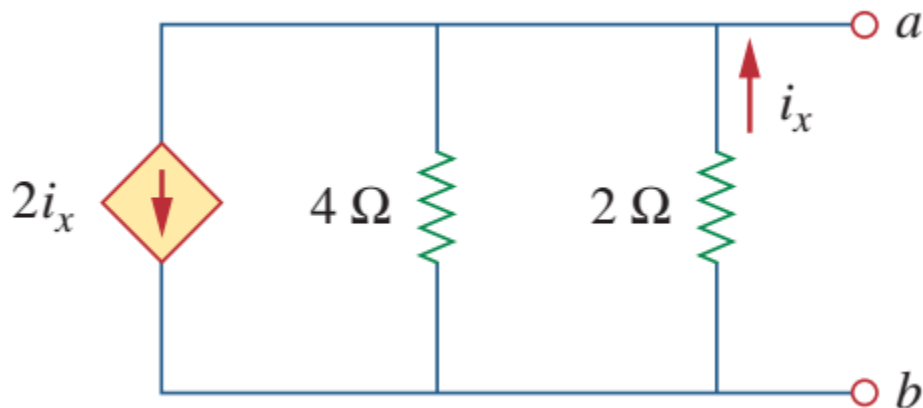

(b)



***I-V* Characteristic of Thévenin Equivalent**

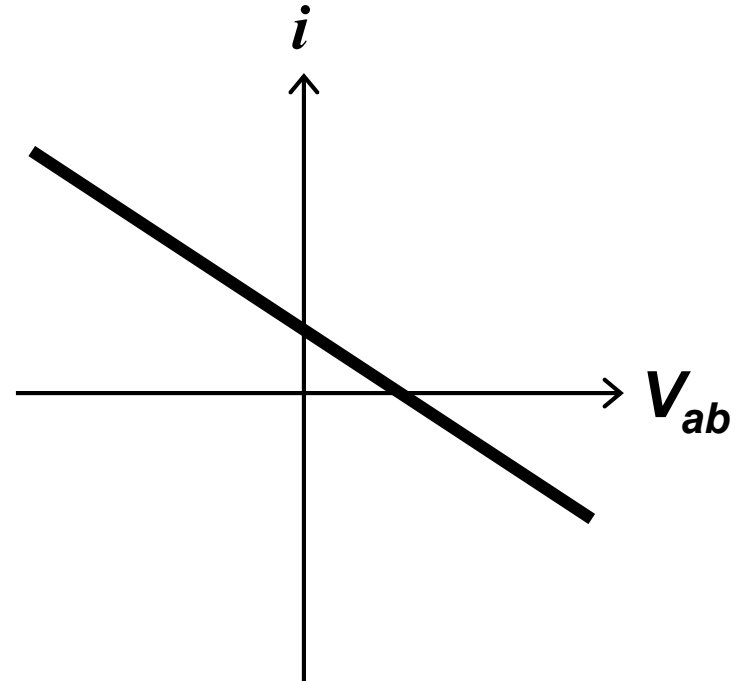
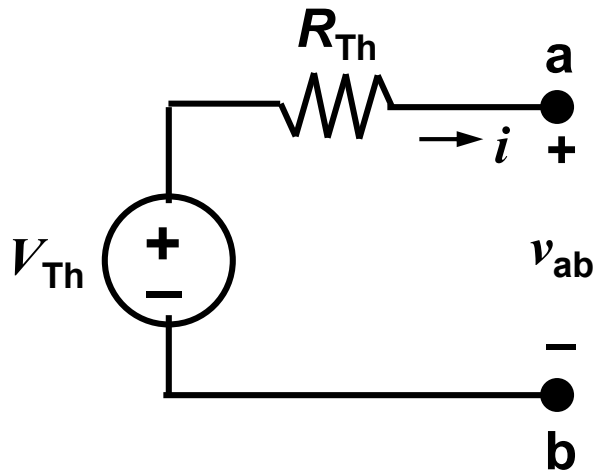



Norton's Theorem

Norton equivalent
circuit

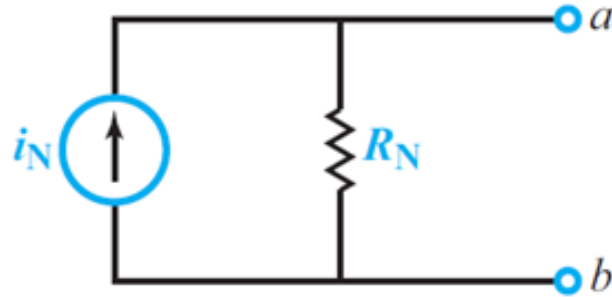



I-V Characteristic of Norton Equivalent

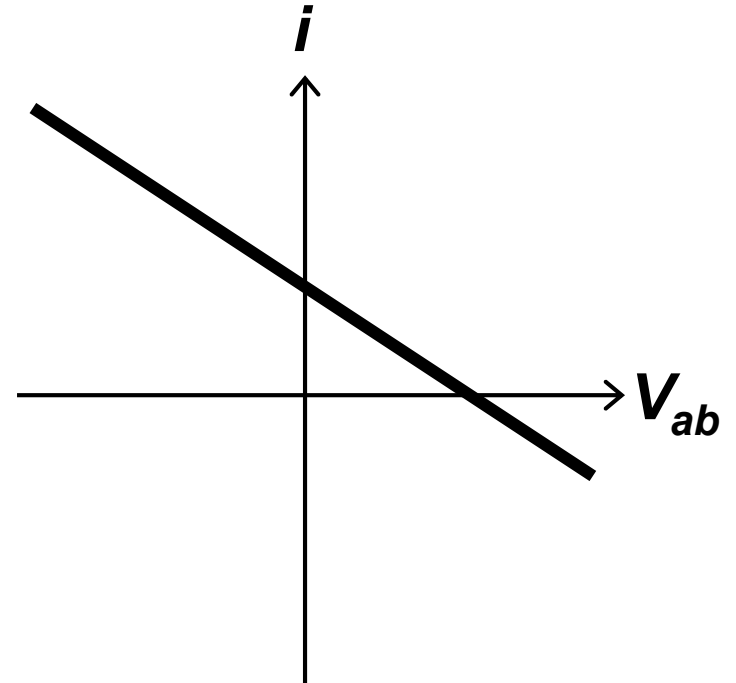
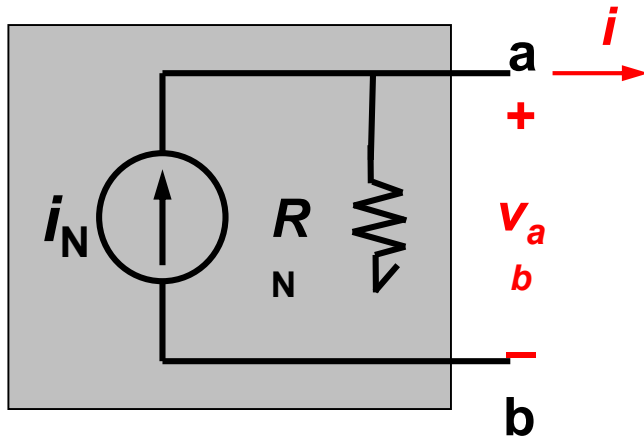

Source Transformation

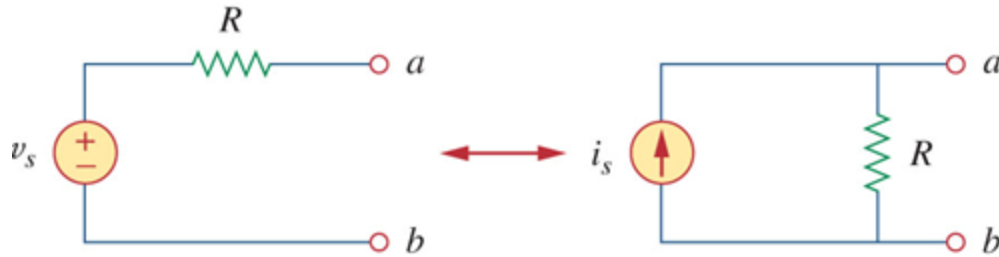

- A source transformation is the process of replacing “a voltage source v_s in series with a resistor R ” **by** “a current source i_s in parallel with a resistor R ”, or vice versa. $V_s/i_s = R$
- These transformations work because the two sources have equivalent behavior at their terminals:
 - If the sources are turned off, resistance at the terminals are both R
 - If the terminals are short circuited, the currents is the same.



- Q1: If $R_2 = 1\Omega$, $I = ?$
- Q2: What if $R_2 = 5\Omega$?

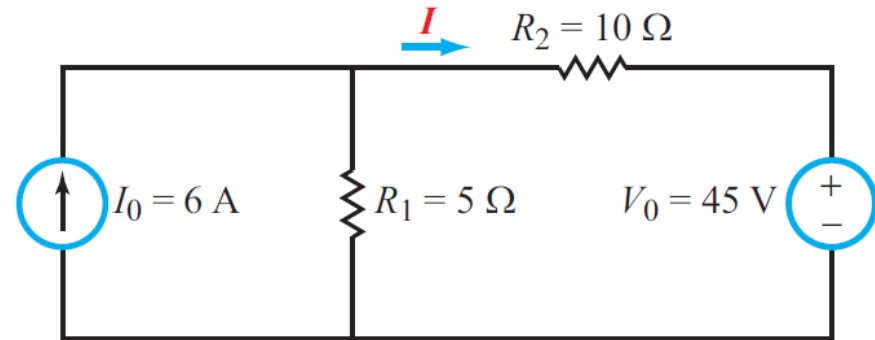



Max Power Transfer

Copyright © The McGraw-Hill Companies, Inc. Permission required for reproduction or display

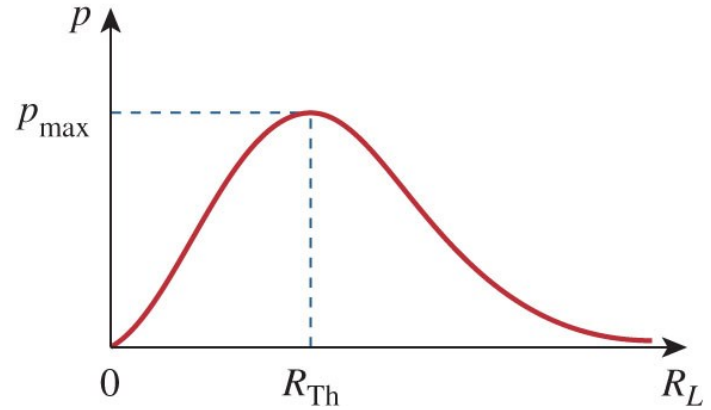
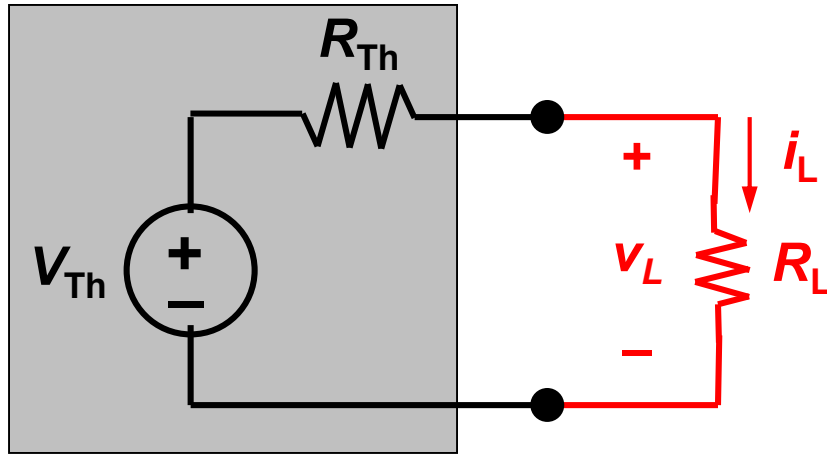

Example

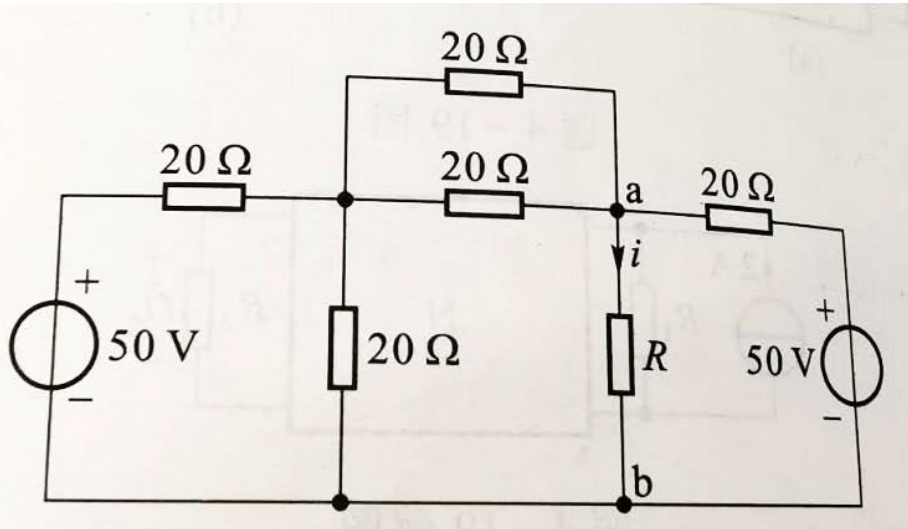

- (1) Calculate the value of R , at which maximum power transferred to R holds.
- (2) Calculate the percentage/ratio: P_R/P_{total}

