



Electric Circuits

Lecture 0 – Course Introduction

Prof. Xinbo ZOU

Office: SIST #3-324

Email: zouxb@shanghaitech.edu.cn



Welcome!

- Lectures

- Tuesday, Thursday 8:15AM – 9:55AM, SIST 1D-104

- Office hours

1. *Wed.: 6:00pm - 7:00pm*

2. *Thur.: 6:00pm - 7:00pm*

- Or by appointment

- TAs:

韦同学 <weijy2025@shanghaitech.edu.cn>;

张同学 <zhangxy12023@shanghaitech.edu.cn>;

Circuit:

a roughly **circular** route that starts and finishes at the same place.

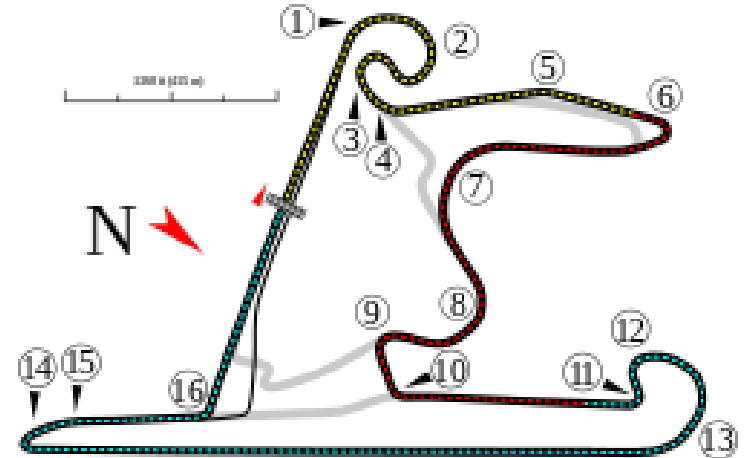

- An *electric circuit* is an interconnection of electrical elements, providing a path for transmitting electric current.

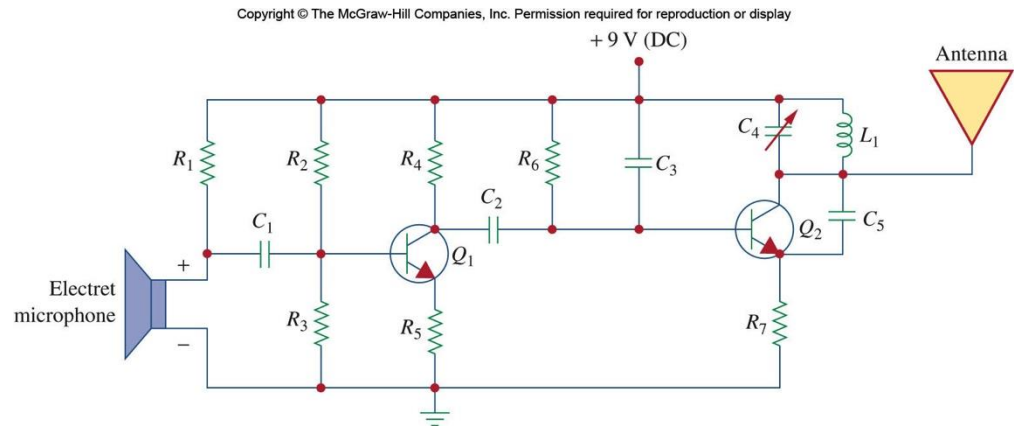
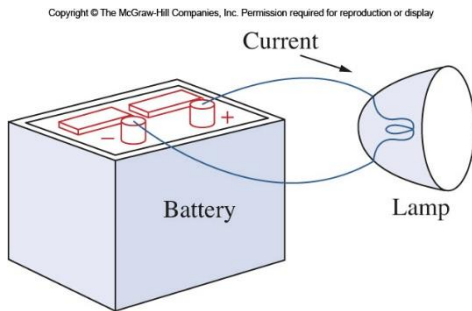

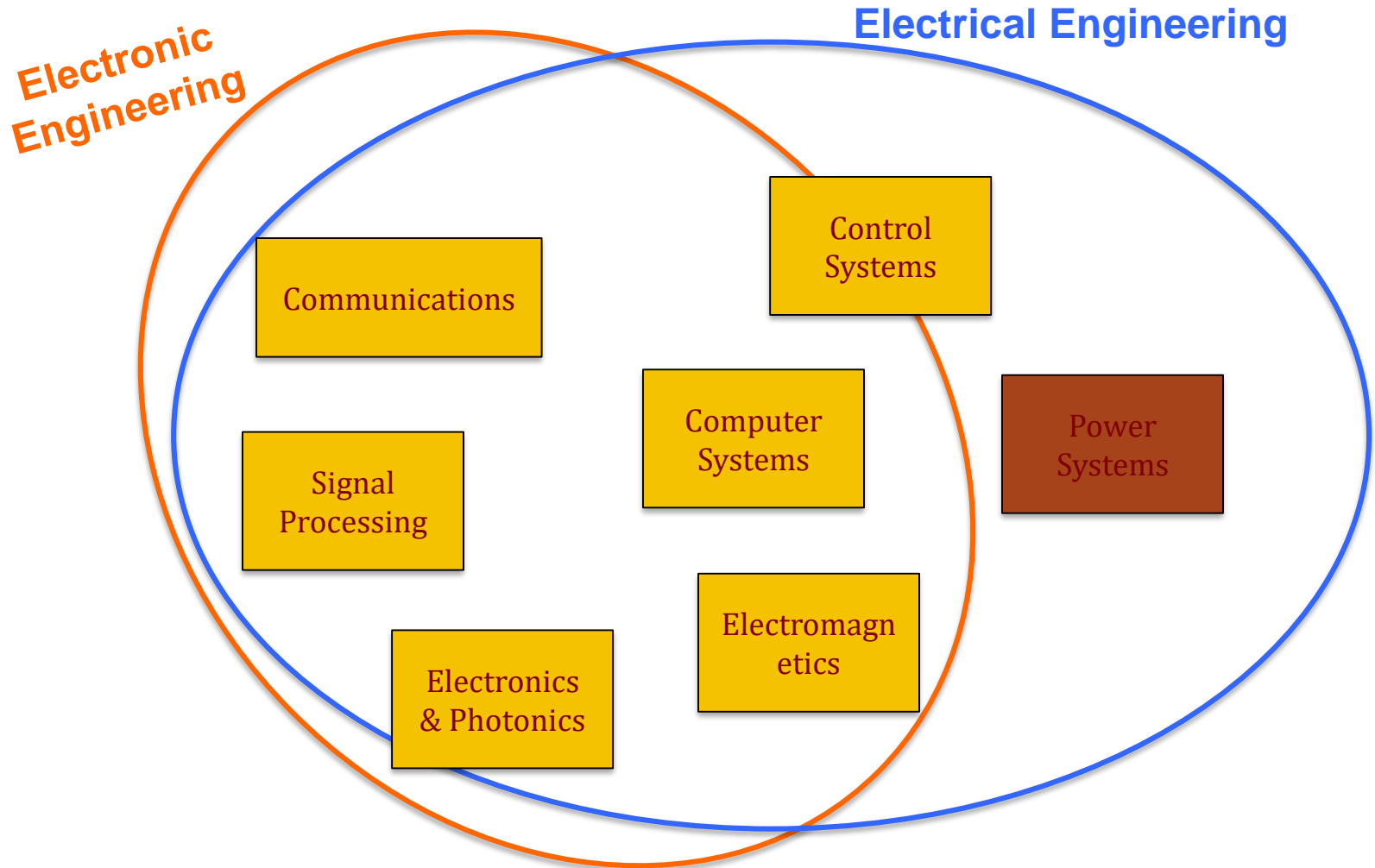

Typically, *circuits are designed* for the following two objectives:

1. To gather, store, process, transport, and present **information**.
2. To distribute, store, and convert **energy** between various forms.



In EE111-Electric Circuits

- You will learn **various analysis methods** to analyze the ***behaviors of electric circuits.***
- The methods combine the ***physicist's models*** of *natural phenomena* with the ***mathematician's tools.***
- ***Behavior analysis often refers to quantitative assessment of electrical element properties: current, voltage, power and so on...***



Textbook & References

- Charles K. Alexander and Matthew N. O. Sadiku, *Fundamentals of Electric Circuits*, 5th edition, McGraw Hill, 2012.
- James W. Nilsson and Susan Riedel, *Electric Circuits*, 9th edition, Prentice Hall, 2010.

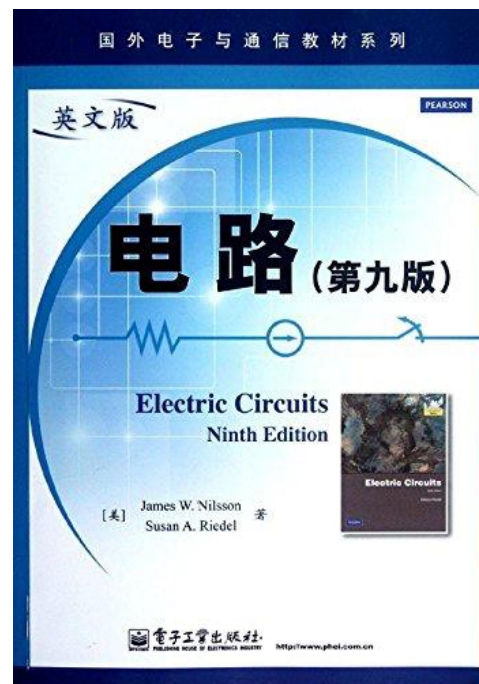
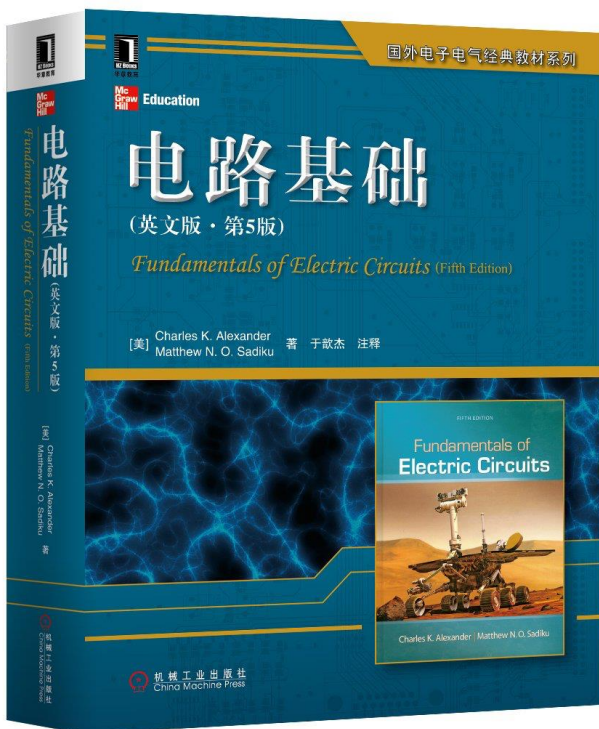



Topics to be Covered in This Course

- Basics: circuit elements; currents, voltages; power/energy;
- Pure resistive circuits:
 - Basic circuit laws (Ohm, Kirchhoff, Wye-Delta etc.)
 - Circuit analysis: nodal analysis and mesh analysis
 - Circuit theorems: Thevenin, Norton, Superposition
 - Operational amplifiers: ideal, inverting/non-inverting, summing and difference)
- Time domain analysis of circuits
 - Capacitor, inductor
 - First-order and second-order circuits
- AC circuits
 - Sinusoidal steady-state analysis and power calculations
 - Three-phase circuits; magnetically coupled circuits
 - Frequency response; transfer function; Bode plots
- Laplace transform



Workload/Grading Policy

- 8 homework assignments: 24%
- 1 Midterm Tests (30%) + 1 Final exam (40%)
 - Midterm Tests: .(tentative)
Thurs. of Week 9, 13th/Nov.
 - Final exam: Week 17-18
 - **NO make-up exams**
- Quizzes and Attendance Check (6%)
 - Quizzes are held in classes and will not be announced in advance.
 - Again no make-up quizzes.



请务必遵守学术道德规范!

• 单次作业抄袭

- 抄袭与被抄袭者相应作业计零分，课程总成绩打**九**折。

• 累计两次作业抄袭

- 抄袭与被抄袭者相应作业计零分，课程总成绩均打**七**折。

• 累计三次作业抄袭者，或者**考试作弊者**

- 课程总成绩**计零分**，同时上报信息学院学术委员会处理。



Lecture 1

Circuit Terminology

Basic Circuit Element

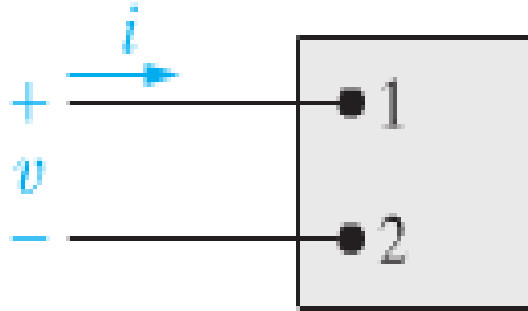

Attributes:

- Two terminals (points of connection)
- Mathematically described in terms of **current** and/or **voltage**
- Cannot be subdivided into other elements

Electric Current

- Charges in motion leads to electric flow (current)

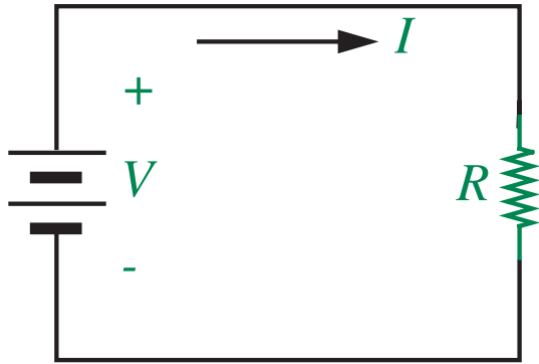

Copyright © The McGraw-Hill Companies, Inc. Permission required for reproduction or display

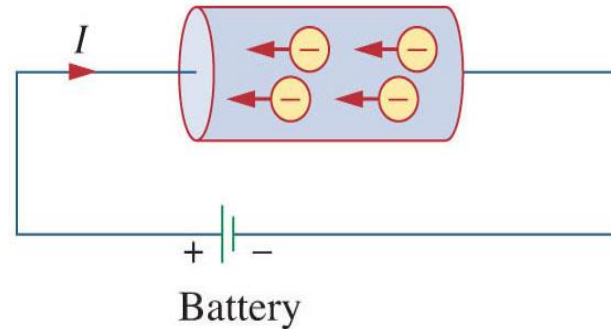

- The current flowing through a surface can be defined as

$$I = \frac{dq}{dt}$$

- Conventional to take the current flow as the movement of positive charges

Unit: Ampere (A)



Reference directions for current

- In order to perform circuit analysis, you need to specify reference directions of currents in an electric circuit.

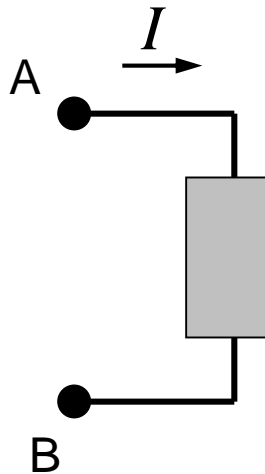

- Reference direction for the current is indicated by an arrow.

In electrical circuits, the path of motion is well defined by wires/circuit elements.

Voltage

- The voltage difference V_{AB} between A and B is the amount of potential energy difference, when moving a unit of charge from A to B .

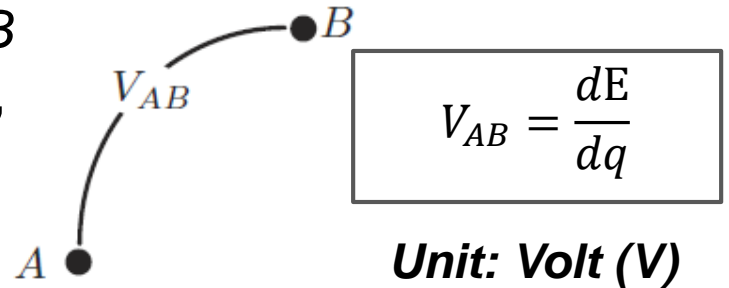

- If charge of Δq is moved from $A \rightarrow B$, the energy **difference** is

$$E_A - E_B = \Delta E = \Delta q \cdot V_{AB}$$

Reference directions for voltage

- In circuit analysis, in order to determine the **voltages of an electric element**, one needs to specify reference directions.

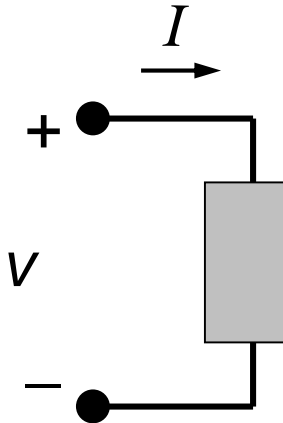

We usually label the terminals of a element as **positive and negative** to denote the **voltage drop** across the element.

$$V = V_+ - V_-$$



Practice



DC versus (v.s.) AC

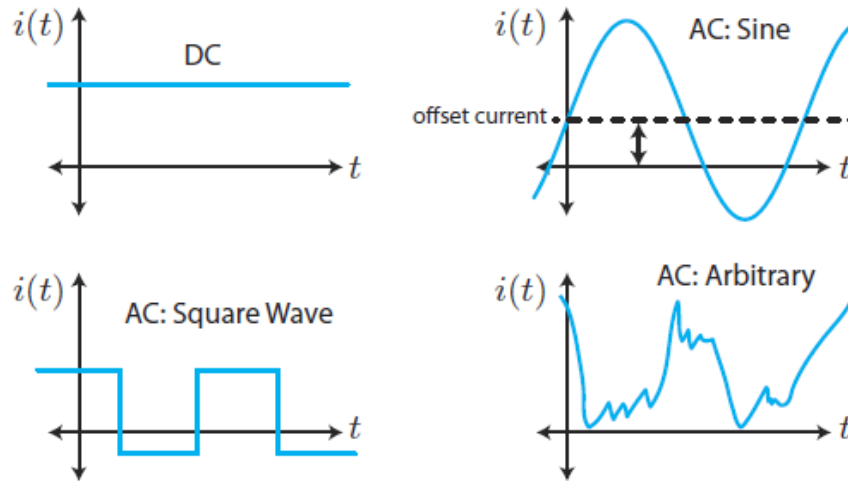

- A constant current is called a “Direct Current” (DC). Otherwise it’s AC (alternating current).
 - Some AC typical waveforms are shown above. Any time-varying current is known as an AC.
 - Note that the sign of the current does not necessarily have to change (the current does not have to alter direction).



Circuit Elements

- 5 ideal basic circuit elements:
 - voltage source
 - current source
 - resistor
 - inductor
 - capacitor

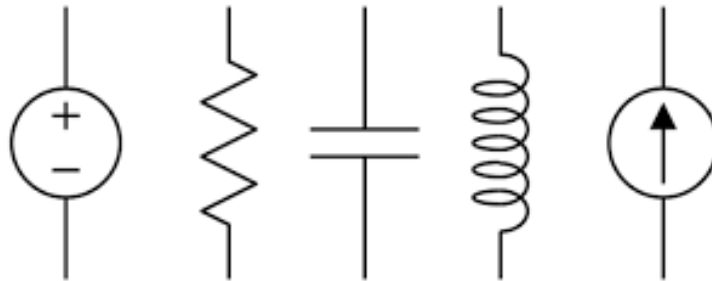



Ideal Voltage Source

- Circuit element that maintains a prescribed voltage across its terminals, **regardless of the current flowing in those terminals.**
- Voltage is known, but current is determined by the circuit to which the source is connected.
- The voltage can be either **independent** or **dependent** on a voltage or current **elsewhere** in the circuit.

Device symbols:

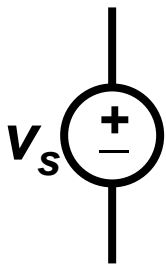

independent

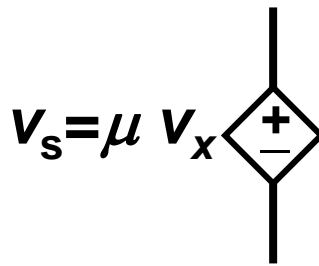

voltage-controlled

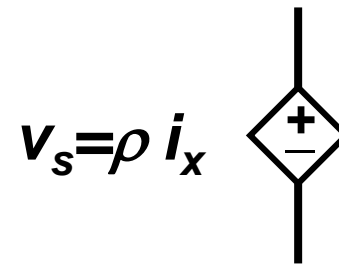

current-controlled



Ideal Current Source

- Circuit element that maintains a prescribed current through its terminals, **regardless of the voltage across those terminals**.
- Current is known, but voltage is determined by the circuit to which the source is connected.
- The current can be either **independent or dependent** on a voltage or current **elsewhere** in the circuit.

Device symbols:

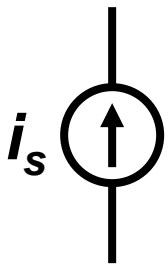

independent

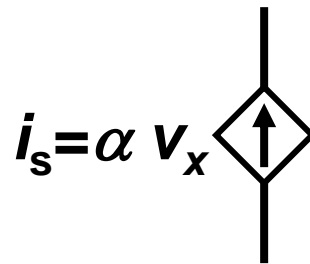

voltage-controlled

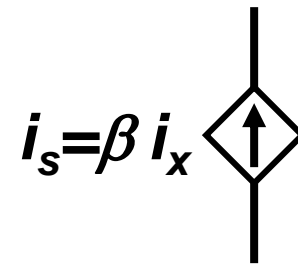

current-controlled



Resistor/Resistance/Conductance

Circuit symbol: 

Unit: Ohm (Ω)

- The current flowing in the resistor is proportional to the voltage across the resistor:

$$V = I R \quad (\text{Ohm's Law})$$

- **Conductance** is the reciprocal of resistance

$$G = \frac{1}{R} = \frac{I}{V}$$

Unit: Siemens (S)



Werner von Siemens
1816-1892



Passive Sign Convention

- Whenever the reference direction for the current in an element is in the direction of the reference voltage drop across the element, use positive sign in any expression that relates the voltage to the current. Otherwise, use a negative sign.

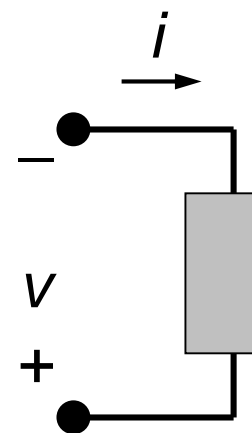
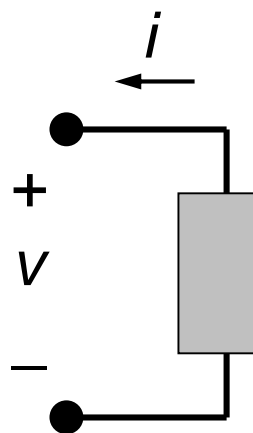
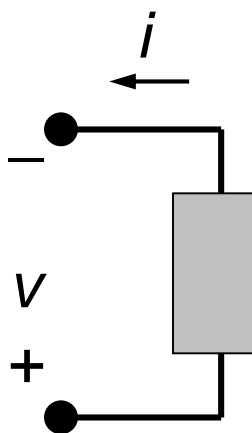
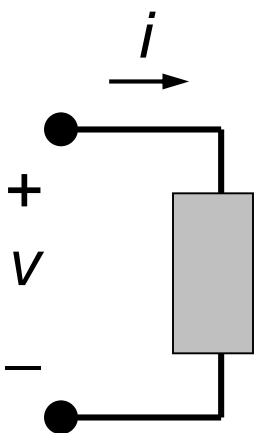



Passive Sign Convention

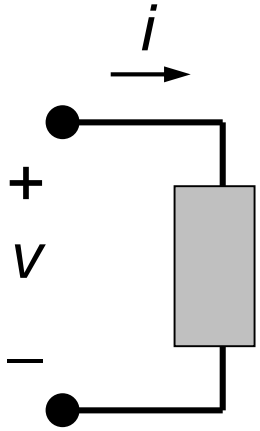

$$p = vi$$

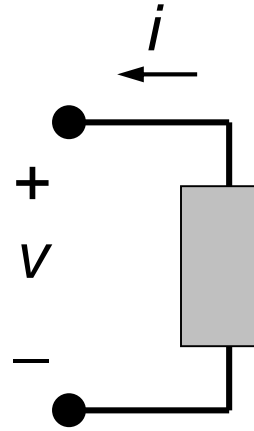
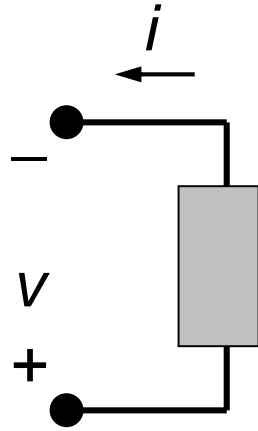

$$p = -vi$$

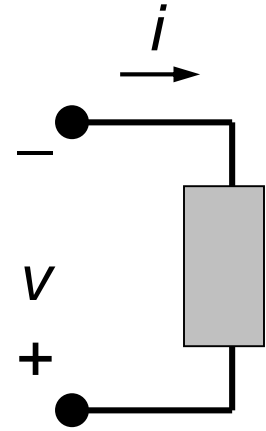



- If $p > 0$, power is absorbed by the element.
 - electrical energy into heat (resistors in toasters), light (light bulbs), or acoustic energy (speakers); by storing energy (charging a battery).
- If $p < 0$, power is extracted from the element.

Power Calculation Exercise

Find the power **absorbed** by each element:

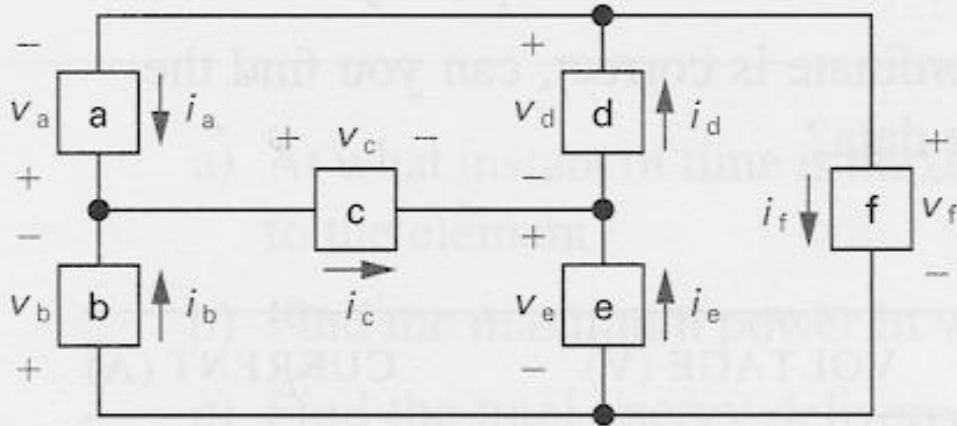

ELEMENT	VOLTAGE (V)	CURRENT (A)
a	-18	-51
b	-18	45
c	2	-6
d	20	-20
e	16	-14
f	36	31

The sum of absorbed element powers must equal zero in any circuit regardless of the elements used to construct the circuit.



I - V Characteristic of Ideal Voltage Source

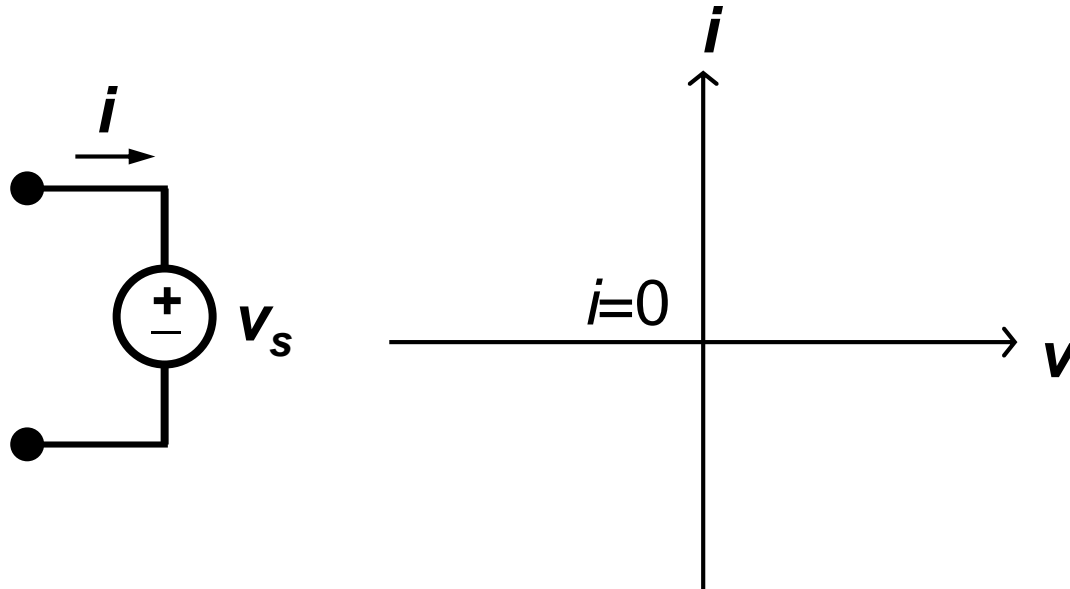

Plot the I - V characteristic for $v_s > 0$. For what values of i does the source absorb power? For what values of i does the source release power?



I - V Characteristic of Ideal Voltage Source

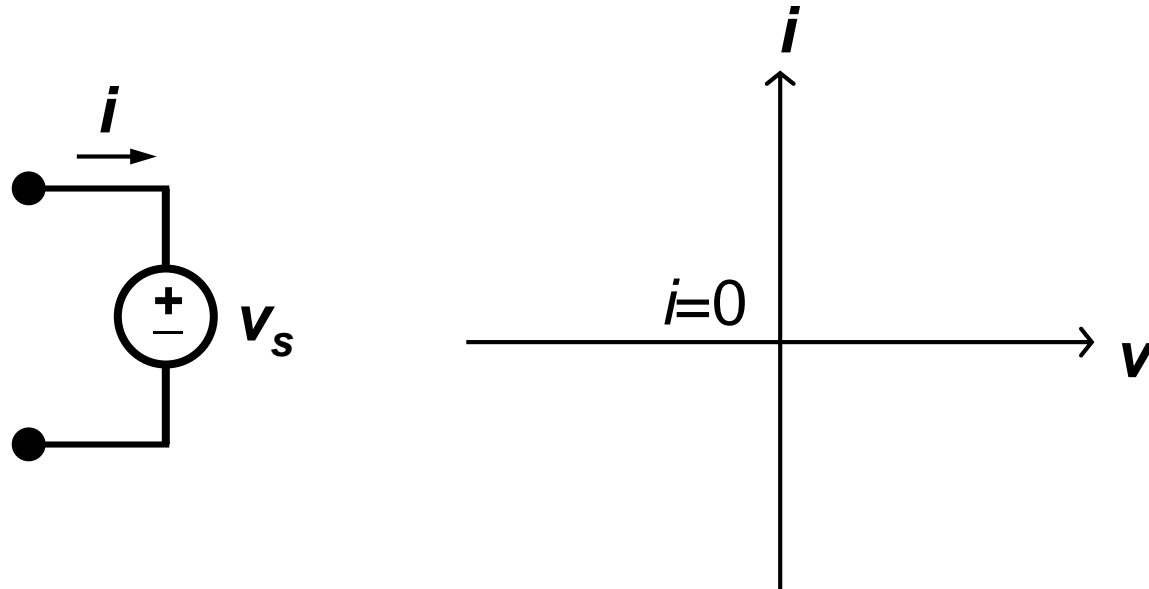

Plot the I - V characteristic for $v_s < 0$. For what values of I does the source absorb power? For what values of i does the source release power?



I - V Characteristic of Ideal Current Source

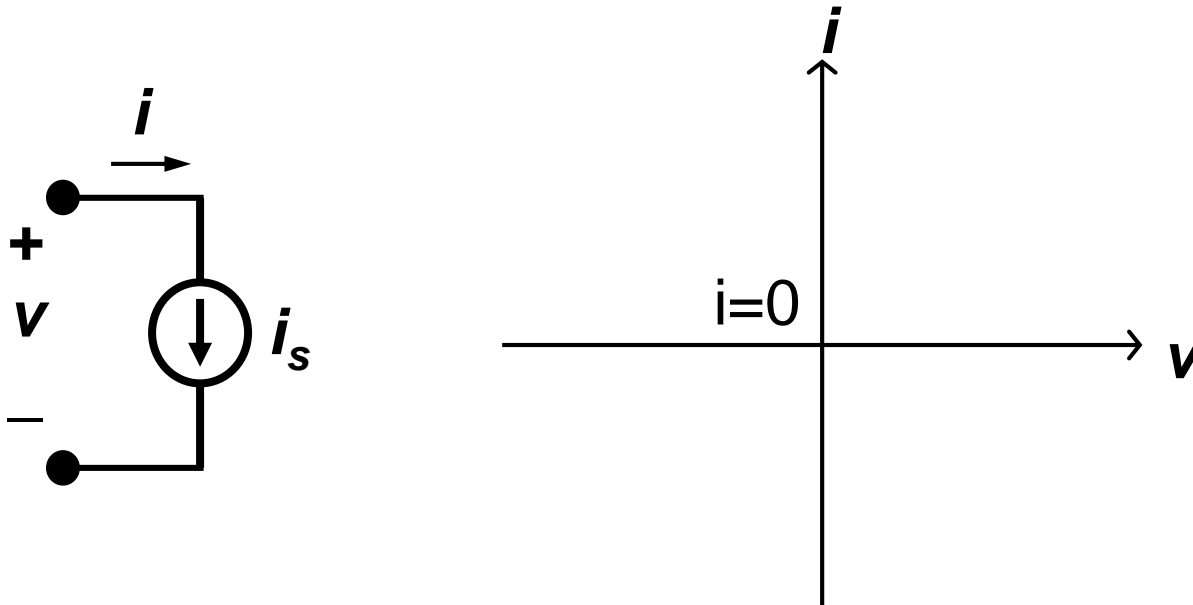

Plot the I - V characteristic for $i_s > 0$. For what values of v does the source absorb power? For what values of v does the source release power?



I - V Characteristic of Ideal Resistor

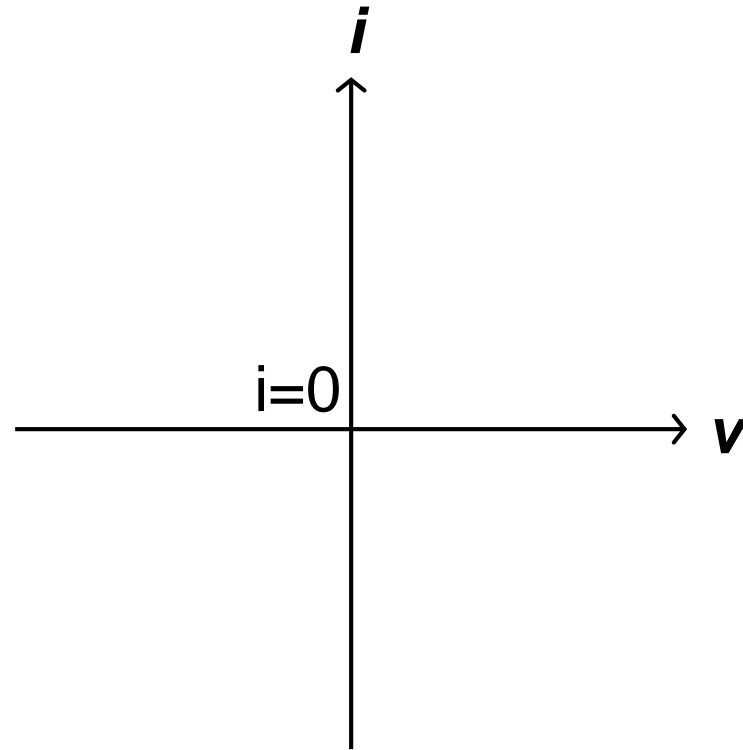
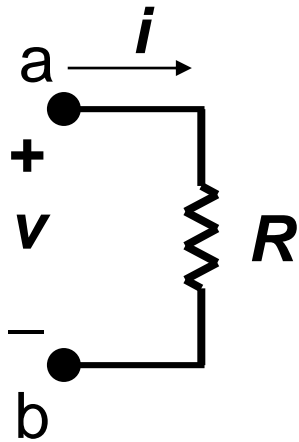

Plot the I - V characteristic for $R = 1 \text{ k ohm}$.
What does the slope mean?



Circuit Elements

- 5 ideal basic circuit elements:
 - voltage source
 - current source
 - resistor
 - inductor
 - capacitor
- } **active elements**, capable of generating electric energy
- } **passive elements**, incapable of generating electric energy

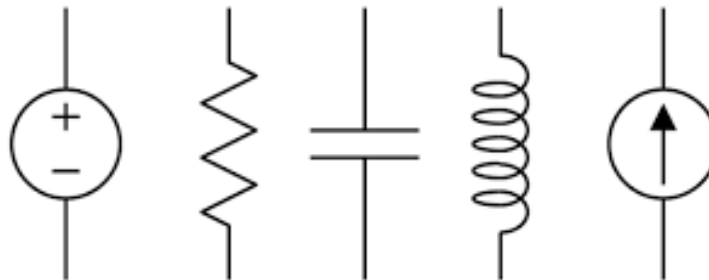



SI Unit prefixes

Prefix	Symbol	10^n	Prefix	Symbol	10^n
yotta	Y	10^{24}	deci	d	10^{-1}
zetta	Z	10^{21}	centi	c	10^{-2}
exa	E	10^{18}	milli	m	10^{-3}
peta	P	10^{15}	micro	μ	10^{-6}
tera	T	10^{12}	nano	n	10^{-9}
giga	G	10^9	pico	p	10^{-12}
mega	M	10^6	femto	f	10^{-15}
kilo	k	10^3	atto	a	10^{-18}
hecto	h	10^2	zepto	z	10^{-21}
deca	da	10^1	yocto	y	10^{-24}

Exercise

- Calculate the power absorbed by each element in the following figure.

Copyright © The McGraw-Hill Companies, Inc. Permission required for reproduction or display

